

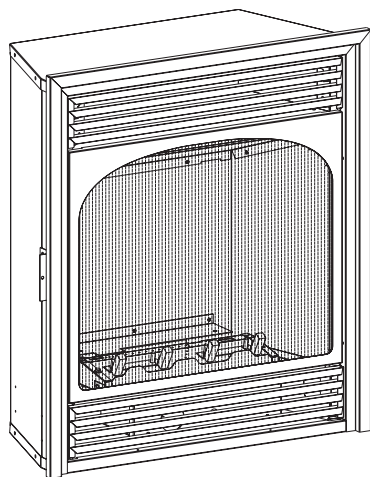

INSTALLATION INSTRUCTIONS AND OWNER'S MANUAL

The *Vail* Vent-Free Gas Fireplaces



This appliance may be installed in an aftermarket, permanently located, manufactured (mobile) home, where not prohibited by local codes.

This appliance is only for use with the type of gas indicated on the rating plate. This appliance is not convertible for use with other gases.

WARNING: If the information in these instructions are not followed exactly, a fire or explosion may result causing property damage, personal injury or loss of life.

- Do not store or use gasoline or other flammable vapors and liquids in the vicinity of this or any other appliance.
- **WHAT TO DO IF YOU SMELL GAS**
 - Do not try to light any appliance.
 - Do not touch any electrical switch; do not use any phone in your building.
 - Immediately call your gas supplier from a neighbor's phone. Follow the gas supplier's instructions.
 - If you cannot reach your gas supplier, call the fire department.
- Installation and service must be performed by a qualified installer, service agency or the gas supplier.

UNVENTED GAS FIREPLACE HYDRAULIC THERMOSTAT MODELS:

VFP24FP2(0,1,2,3)L(N,P)-1

MILLIVOLT MODELS:

VFP24FP3(0,1,2,3)L(N,P)-1

VFP24FP3(0,1,2,3)L10(N,P)-1 (10,000 BTU UNIT)

NATIONAL
FIREPLACE
INSTITUTE



CERTIFIED
www.nficertified.org

We suggest that our gas hearth products be installed and serviced by professionals who are certified in the U.S. by the National Fireplace Institute® (NFI) as NFI Gas Specialists.

Installer: Leave this manual with the appliance.
Consumer: Retain this manual for future reference.

This is an unvented gas-fired heater. It uses air (oxygen) from the room in which it is installed. Provisions for adequate combustion and ventilation air must be provided. Refer to page 6.

WARNING: If not installed, operated and maintained in accordance with the manufacturer's instructions, this product could expose you to substances in fuel or from fuel combustion which can cause death or serious illness.

WATER VAPOR: A BY-PRODUCT OF UNVENTED ROOM HEATERS

Water vapor is a by-product of gas combustion. An unvented room heater produces approximately one (1) ounce (30ml) of water for every 1,000 BTU's (.3KW's) of gas input per hour. Refer to page 6.

TABLE OF CONTENTS

SECTION	PAGE
Important Safety Information	3
Safety Information for Users of LP Gas	4
Introduction	5
Specifications	6
Water Vapor: A By-Product of Unvented Room Heaters	6
Provisions for Adequate Combustion and Ventilation Air	6-7
Gas Supply	8
Clearances	9
Combustible Material	9
Installation of Fireplace Into Mantel	10
Built-In Fireplace Installation	11
Placement of Glowing Embers (Rock Wool)	12
Operation Instructions/Flame Appearance	12
Millivolt Lighting Instructions	13
Hydraulic Thermostat Lighting Instructions	14
Pilot Flame Characteristics	15-16
Main Burner and Thermostat Operation	16
Wiring	17
Troubleshooting	18
Parts List	19
Parts View	20
Optional Brick Liner Installation Instructions	21
Optional Blower Installation Instructions	22-25
Parts List and Parts View for Optional Trim Kits	26
Master Parts Distributor List	27
How To Order Repair Parts	27

IMPORTANT SAFETY INFORMATION

THIS IS A HEATING APPLIANCE

⚠ DANGER: Indicates a hazardous situation which, if not avoided, will result in death or serious injury.

⚠ WARNING: Indicates a hazardous situation which, if not avoided, could result in death or serious injury.

⚠ CAUTION: Indicates a hazardous situation which, if not avoided, could result in minor or moderate injury.

NOTICE: Addresses practices not related to personal injury.

- An unvented room heater having an input rating of more than 6,000 Btu per hour shall not be installed in a bathroom.
- An unvented room heater having an input rating of more than 10,000 Btu per hour shall not be installed in a bedroom or bathroom.
- Due to high temperatures, the appliance should be located out of traffic and away from furniture and draperies.
- Children and adults should be alerted to the hazard of high surface temperature and should stay away to avoid burns or clothing ignition.
- Young children should be carefully supervised when they are in the same room with the appliance.
- Do not place clothing or other flammable material on or near the appliance.
- Installation and repair should be done by a **QUALIFIED SERVICE PERSON**. This appliance should be inspected before use and at least annually by a professional service person. More frequent cleaning may be required due to excessive lint from carpeting, bedding materials, etc. It is imperative that control compartments, burners and circulating air passageways of the appliance be kept clean.
- **DO NOT** use this fireplace if any part has been under water. Immediately call a qualified service technician to inspect the fireplace and to replace any part of the control system and any gas control which has been under water.

- You must operate fireplace with fireplace screen closed in place. Do not close glass doors while operating heater.
- Do not place trash, logs or other articles on the log set during operation.
- During manufacturing, fabricating and shipping, various components of this appliance are treated with certain oils, films or bonding agents. These bonding agents are not harmful but may produce annoying smoke and smells as they are burned off during initial operation of the appliance. This is a normal temporary occurrence. A window should be opened during the initial bake out period.
- Correct installation of the logs, proper location of the fireplace and annual cleaning are necessary to avoid potential problems with sooting. Sooting, resulting from improper installation or operation, can settle on surfaces outside the fireplace. See instructions for proper installation.
- **⚠ WARNING:** Do not allow fans to blow directly into the fireplace. Avoid any drafts that alter burner flame patterns.
- **⚠ WARNING:** Do not use a blower insert, heat exchanger insert or other accessory not approved for use with this heater.
- **⚠ WARNING!** This fireplace needs fresh air for ventilation to operate properly. This fireplace has an ODS (oxygen depletion sensor) which will shut off the fireplace if adequate fresh air is not available.
- Keep appliance area clear and free from combustible materials, gasoline and other flammable vapors and liquids.

⚠ WARNING

When used without adequate combustion and ventilation air, heater may give off **CARBON MONOXIDE**, an odorless, poisonous gas.

Do not install heater until all necessary provisions are made for combustion and ventilation air. Consult the written instructions provided with the heater for information concerning combustion and ventilation air. In the absence of instructions, refer to the National Fuel Gas Code, ANSI Z223.1, Section 5.3 or applicable local codes.

This heater is equipped with a **PILOT LIGHT SAFETY SYSTEM** designed to turn off the heater if not enough fresh air is available.

DO NOT TAMPER WITH PILOT LIGHT SAFETY SYSTEM!

If heater shuts off, do not relight until you provide fresh air.
If heater keeps shutting off, have it serviced. Keep burner and control compartment clean.

CARBON MONOXIDE POISONING MAY LEAD TO DEATH.

Early signs of carbon monoxide poisoning resemble the flu, with headache, dizziness and/or nausea. If you have these signs, heater may not be working properly. Get fresh air at once! Have heater serviced.

Some people — pregnant women, persons with heart or lung disease, anemia, those under the influence of alcohol, those at high altitudes — are more affected by carbon monoxide than others.

The pilot light safety system senses the depletion of oxygen at its location. If this heater is installed in a structure having a high vertical dimension, the possibility exists that the oxygen supply at the higher levels will be less than that at the heater. In this type of application, a fan to circulate the structure air will minimize this effect. The use of this fan will also improve the comfort level in the structure. When a fan is used to circulate air, it should be located so that the air flow is not directed at the burner.

SAFETY INFORMATION FOR USERS OF LP-GAS

Propane (LP-Gas) is a flammable gas which can cause fires and explosions. In its natural state, propane is odorless and colorless. You may not know all the following safety precautions which can protect both you and your family from an accident. Read them carefully now, then review them point by point

with the members of your household. Someday when there may not be a minute to lose, everyone's safety will depend on knowing exactly what to do. If, after reading the following information, you feel you still need more information, please contact your gas supplier.

LP-GAS WARNING ODOR

If a gas leak happens, you should be able to smell the gas because of the odorant put in the LP-Gas. That's your signal to go into immediate action!

- Do not operate electric switches, light matches, use your phone. Do not do anything that could ignite the gas.
- Get everyone out of the building, vehicle, trailer, or area. Do that IMMEDIATELY.
- Close all gas tank or cylinder supply valves.
- LP-Gas is heavier than air and may settle in low areas such as basements. When you have reason to suspect a gas leak, keep out of basements and other low areas. Stay out until firefighters declare them to be safe.
- Use your neighbor's phone and call a trained LP-Gas service person and the fire department. Even though you may not continue to smell gas, do not turn on the gas again. Do not re-enter the building, vehicle, trailer, or area.
- Finally, let the service man and firefighters check for escaped gas. Have them air out the area before you return. Properly trained LP-Gas service people should repair the leak, then check and relight the gas appliance for you.

NO ODOR DETECTED - ODOR FADE

Some people cannot smell well. Some people cannot smell the odor of the chemical put into the gas. You must find out if you can smell the odorant in propane. Smoking can decrease your ability to smell. Being around an odor for a time can affect your sensitivity or ability to detect that odor. Sometimes other odors in the area mask the gas odor. People may not smell the gas odor or their minds are on something else. Thinking about smelling a gas odor can make it easier to smell.

The odorant in LP-gas is colorless, and it can fade under some circumstances. For example, if there is an underground leak, the movement of the gas through soil can filter the odorant. Odorants in LP-Gas also are subject to oxidation. This fading can occur if there is rust inside the storage tank or in iron gas pipes.

The odorant in escaped gas can adsorb or absorb onto or into walls, masonry and other materials and fabrics in a room. That will take some of the odorant out of the gas, reducing its odor intensity.

LP-Gas may stratify in a closed area, and the odor intensity could vary at different levels. Since it is heavier than air, there may be more odor at lower levels. Always be sensitive to the slightest gas odor. If you detect any odor, treat it as a serious leak. Immediately go into action as instructed earlier.

SOME POINTS TO REMEMBER

- **Learn to recognize the odor of LP-gas.** Your local LP-Gas Dealer can give you a "Scratch and Sniff" pamphlet. Use it to find out what the propane odor smells like. If you suspect that your LP-Gas has a weak or abnormal odor, call your LP-Gas Dealer.
- If you are not qualified, do not light pilot lights, perform service, or make adjustments to appliances on the LP-Gas system. If you are qualified, consciously think about the odor of LP-Gas prior to and while lighting pilot lights or performing service or making adjustments.
- Sometimes a basement or a closed-up house has a musty smell that can cover up the LP-Gas odor. Do not try to light pilot lights, perform service, or make adjustments in an area where the conditions are such that you may not detect the odor if there has been a leak of LP-Gas.
- Odor fade, due to oxidation by rust or adsorption on walls of new cylinders and tanks, is possible. Therefore, people should be particularly alert and careful when new tanks or cylinders are placed in service. Odor fade can occur in new tanks, or reinstalled old tanks, if they are filled and allowed to set too long before refilling. Cylinders and tanks which have been out of service for a time may develop internal rust which will cause odor fade. If such conditions are suspected to exist, a periodic sniff test of the gas is advisable. **If you have any question about the gas odor, call your LP-gas dealer. A periodic sniff test of the LP-gas is a good safety measure under any condition.**
- If, at any time, you do not smell the LP-Gas odorant and you think you should, assume you have a leak. Then take the same immediate action recommended above for the occasion when you do detect the odorized LP-Gas.
- If you experience a complete "gas out," (the container is under no vapor pressure), turn the tank valve off immediately. If the container valve is left on, the container may draw in some air through openings such as pilot light orifices. If this occurs, some new internal rusting could occur. If the valve is left open, then treat the container as a new tank. Always be sure your container is under vapor pressure by turning it off at the container before it goes completely empty or having it refilled before it is completely empty.

INTRODUCTION

Instructions to Installer

1. Installer must leave instruction manual with owner after installation.
2. Installer must have owner fill out and mail warranty card supplied with unvented room heater.
3. Installer should show owner how to start and operate unvented room heater.

Always consult your local Building Department regarding regulations, codes or ordinances which apply to the installation of an unvented room heater.

This appliance may be installed in an aftermarket* manufactured (mobile) home, where not prohibited by state or local codes.

*Aftermarket: Completion of sale, not for purpose of resale, from the manufacturer.

This appliance is only for use with the type of gas indicated on the rating plate. This appliance is not convertible for use with other gases.

Well Head Gas Installations

Some natural gas utilities use "well head" gas. This may affect the Btu output of the unit. Contact the gas company for the heating value. Contact the manufacturer or your gas company before changing spud/orifice size.

WARNING

ANY CHANGE TO THIS HEATER OR ITS CONTROLS CAN BE DANGEROUS.

Improper installation or use of the heater can cause serious injury or death from fire, burns, explosion or carbon monoxide poisoning.

Operation

This unvented fireplace requires no outside venting. This unvented fireplace is designed for vent-free operation with flue damper closed. State and local codes in some areas prohibit the use of unvented fireplace.

Millivolt controls

The valve regulator controls the burner pressure which should be checked at the pressure test point. Turn captured screw counter clockwise 2 or 3 turns and then place tubing to pressure gauge over test point (Use test point "A" closest to control knob). After taking pressure reading, be sure and turn captured screw clockwise firmly to re-seal. Do not over torque. Check for gas leaks.

Millivolt System,

When you ignite the pilot, the thermocouple produces millivolts (electrical current) which energizes the magnet in the gas valve. After 30 seconds to 1 minute time period you can release the gas control knob and the pilot will stay ON. Allow your pilot flame to operate an additional one (1) to two (2) minutes before you turn the gas control knob from the PILOT position to the ON position. This time period allows the millivolts (electrical current) to build-up to a sufficient level allowing the gas control to operate properly.

WARNING

This appliance is equipped for (natural gas or propane) gas. Field conversion is not permitted.

General Information

This series is design certified in accordance with American National Standard Z21.11.2 by the Canadian Standards Association as an Unvented Room Heater and should be installed according to these

25783-4-0411

instructions.

Any alteration of the original design, installed other than as shown in these instructions or use with a type of gas not shown on the rating plate is the responsibility of the person and company making the change.

Important

All correspondence should refer to complete Model Number, Serial Number and type of gas.

Attention: During initial use of log you will detect an odor as the log is cured. Also, during the curing process the ceramic log will burn with a yellow flame.

Notice: During initial firing of this unit, its paint will bake out, and smoke will occur. To prevent triggering of smoke alarms, ventilate the room in which the unit is installed.

Installation on Rugs and Tile

If this appliance is installed directly on carpeting, tile or other combustible material other than wood flooring the appliance shall be installed on a metal or wood panel extending the full width and depth of the appliance.

The base referred to above does not mean the fire-proof base as used on wood stoves. The protection is for rugs that are extremely thick and light colored tile.

Solid-fuels shall not be burned in a masonry or *UL 127* factory-built fireplace in which an unvented room heater is installed.

Qualified Installing Agency

Installation and replacement of gas piping, gas utilization equipment or accessories and repair and servicing of equipment shall be performed only by a qualified agency. The term "qualified agency" means any individual, firm, corporation or company which either in person or through a representative is engaged in and is responsible for (a) the installation or replacement of gas piping or (b) the connection, installation, repair or servicing of equipment, who is experienced in such work, familiar with all precautions required and has complied with all the requirements of the authority having jurisdiction.

State of Massachusetts: The installation must be made by a licensed plumber or gas fitter in the Commonwealth of Massachusetts.

Sellers of unvented propane or natural gas-fired supplemental room heaters shall provide to each purchaser a copy of 527 CMR 30 upon sale of the unit.

In the State of Massachusetts, unvented propane and natural gas-fired space heaters shall be prohibited in bedrooms and bathrooms.

The installation must conform with local codes or, in the absence of local codes, with the *National Fuel Gas Code, ANSI Z223.1.**

*Available from the American National Standards Institute, Inc. 1430 Broadway, New York, N.Y. 10018.

High Altitudes

For altitudes/elevations above 2,000 feet (610m), ratings should be reduced at the rate of 4 percent for each 1,000 feet (305m) above sea level. Contact the manufacturer or your gas company before changing spud/orifice size.

WARNING

Failure to keep the primary air opening(s) of the burner(s) clean may result in sooting and property damage.

SPECIFICATIONS

Model	VFP24FP3*L	VFP24FP2*L	VFP24FP3*L10
Input Max.	20,000	20,000	10,000
Min.	14,000	10,000	10,000
Fireplace Dimensions			
Height	26 3/8"	26 3/8"	26 3/8"
Depth	10 7/8"	10 7/8"	10 7/8"
Front Width	22 5/8"	22 5/8"	22 5/8"
Rear Width	17 1/4"	17 1/4"	17 1/4"
Gas Inlet	3/8"	3/8"	3/8"

* Indicates optional accessories that may be installed.

Accessories	
FBB6	Automatic Blower
VPP1A-22	Aged Brick Liner
VFF24BR-1	Brass Trim Kit
VFF24SS-1	Stainless Steel Trim Kit
VFF24HP-1	Hammered Pewter Trim Kit
Accessories for Millivolt Models Only	
FRBC	Battery Operated Remote Control
FRBTC	Battery Operated Remote Control w/Thermostat
FREC	Electric Remote Control
FWS	Wall Switch
TMV	Wall Thermostat, Millivolt - Reed Switch
TRW	Wireless Remote Wall Thermostat

WATER VAPOR: A BY-PRODUCT OF UNVENTED ROOM HEATERS

Water vapor is a by-product of gas combustion. An unvented room heater produces approximately one (1) ounce (30ml) of water for every 1,000 BTU's (.3KW's) of gas input per hour. .

Unvented room heaters are recommended as supplemental heat (a room) rather than a primary heat source (an entire house). In most supplemental heat applications, the water vapor does not create a problem. In most applications, the water vapor enhances the low humidity atmosphere experienced during cold weather.

The following steps will help insure that water vapor does not become a problem.

1. Be sure the heater is sized properly for the application, including ample combustion air and circulation air.
2. If high humidity is experienced, a dehumidifier may be used to help lower the water vapor content of the air.
3. Do not use an unvented room heater as the primary heat source.

PROVISIONS FOR ADEQUATE COMBUSTION & VENTILATION AIR

This heater shall not be installed in a confined space or unusually tight construction unless provisions are provided for adequate combustion and ventilation air.

A confined space is an area with volume less than 50 cubic feet per 1,000 Btuh of the combined input rates of all appliances drawing combustion air from that space. Small areas such as equipment rooms are confined spaces. Furnaces installed in a confined space which supply heated air to areas outside the space must draw return air from outside the space through tightly sealed return air ducts. A confined space must have 2 openings into the space for combustion air. One opening must be within 12 inches of the ceiling and the other must be within 12 inches of the floor. The required sizing of these openings is determined by whether inside or outside air is used to support combustion, the method by which the air is brought to the space (vertical or horizontal duct) and by the total input rate of all appliances in the space.

Unusually Tight Construction

The air that leaks around doors and windows may provide enough fresh air for combustion and ventilation. However, in buildings of unusually tight construction, you must provide additional fresh air.

Unusually tight construction is defined as construction where:

- a. Walls and ceilings exposed to the outside atmosphere have a continuous water vapor retarder with a rating of one perm or less with openings gasketed or sealed, and
- b. Weatherstripping has been added on openable windows and doors, and
- c. Caulking or sealants are applied to areas such as joints around window and door frames, between sole plates and floors, between wall-ceiling joints, between wall panels, at

penetrations for plumbing, electrical, and gas lines, and at other openings.

If your home meets all of the three criteria above, you must provide additional fresh air. See "**Ventilation Air From Outdoors,**" page 7.

Determining if You Have a Confined or Unconfined Space

Use this worksheet to determine if you have a confined or unconfined space.

Space: Includes the room in which you will install heater plus any adjoining rooms with doorless passageways or ventilation grills between the rooms.

1. Determine the volume of the space (length x width x height).

$$\text{Length} \times \text{Width} \times \text{Height} = \text{_____ cu. ft. (volume of space)}$$
 Example: Space size 16 ft. (length) x 10 ft. (width) x 8 ft. (ceiling height) = 1,280 cu. ft. (volume of space)

If additional ventilation to adjoining room is supplied with grills or openings, add the volume of these rooms to the total volume of the space.

2. Divide the space volume by 50 cubic feet to determine the maximum BTU/Hr the space can support.

$$\text{_____ (volume of space)} \div 50 \text{ cu. ft.} = \text{(maximum BTU/Hr the space can support)}$$
 Example: 1,280 cu. ft. (volume of space) \div 50 cu. ft. = 25.6 or 25,600 (maximum BTU/Hr the space can support)

3. Add the BTU/Hr of all fuel burning appliances in the space.

Vent-free heater	_____	BTU/Hr
Gas water heater	_____	BTU/Hr
Gas furnace	_____	BTU/Hr
Vented gas heater	_____	BTU/Hr
Gas fireplace logs	_____	BTU/Hr
Other gas appliances*	+ _____	BTU/Hr
Total	= _____	BTU/Hr

Example: Vented gas heater	20,000	BTU/Hr
Vent-free heater	+ 18,000	BTU/Hr
Total	= 38,000	BTU/Hr

*Do not include direct-vent gas appliances. Direct vent draws combustion air from the outdoors and vents to the outdoors.

4. Compare the maximum BTU/Hr the space can support with the actual amount of BTU/Hr used.

_____ BTU/Hr (maximum the space can support)
 _____ BTU/Hr (actual amount of BTU/Hr used)

Example:		
25,600	BTU/Hr (maximum the space can support)	
38,000	BTU/Hr (actual amount of BTU/Hr used)	

⚠ WARNING

If the area in which the heater may be operated is smaller than that defined as an unconfined space or if the building is of unusually tight construction, provide adequate combustion and ventilation air by one of the methods described in the National Fuel Gas Code, ANSI Z223.1, Section 5.3 or applicable local codes.

The space in the above example is a confined space because the actual BTU/Hr used is more than the maximum BTU/HR the space can support. You must provide additional fresh air. Your options are as follows:

- A. Rework worksheet, adding the space of an adjoining room. If the extra space provides an unconfined space, remove door to adjoining room or add ventilation grills between rooms. See **Ventilation Air From Inside Building**.
- B. Vent room directly to the outdoors. See **Ventilation Air From Outdoors**.
- C. Install a lower BTU/Hr heater, if lower BTU/Hr size makes room unconfined.

If the actual BTU/Hr used is less than the maximum BTU/Hr the space can support, the space is an unconfined space. You will need no additional fresh air ventilation.

⚠ WARNING

You must provide additional ventilation air in a confined space.

VENTILATION AIR

Ventilation Air From Inside Building

This fresh air would come from an adjoining unconfined space. When ventilating to an adjoining unconfined space, you must provide two permanent openings: one within 12" of the ceiling and one within 12" of the floor on the wall connecting the two spaces (see options 1 and 2, Figure 1). You can also remove door into adjoining room (see option 3, Figure 1). Each ventilation grill or opening shall have a minimum free area of one square inch per 1,000 BTU/HR of the total input rating of the gas equipment in the confined space.

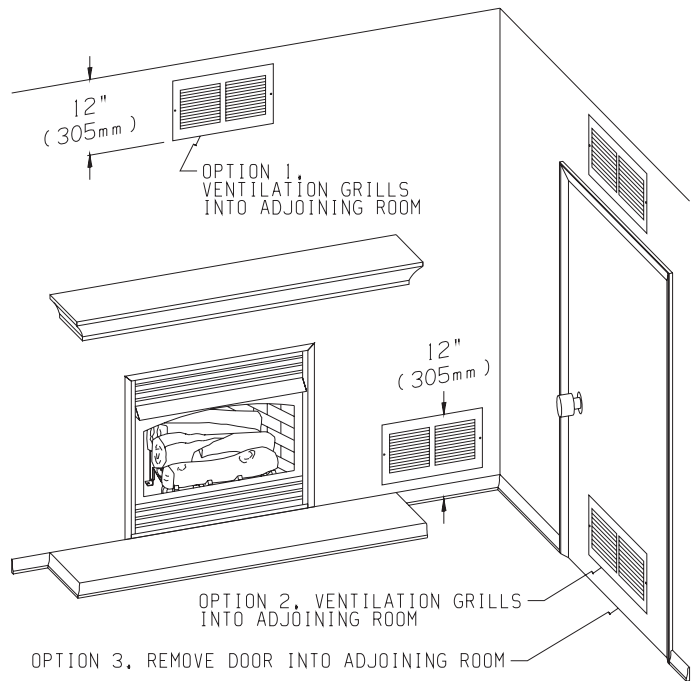

Figure 1

⚠ WARNING

Rework worksheet, adding the space of the adjoining unconfined space. The combined spaces must have enough fresh air to supply all appliances in both spaces.

Ventilation Air From Outdoors

Provide extra fresh air by using ventilation grills or ducts. You must provide two permanent openings: one within 12" of the ceiling and one with 12" of the floor. Connect these items directly to the outdoors or spaces open to the outdoors. These spaces include attics and crawl spaces. In most cases for direct communication with the outdoors or direct communication through a vertical duct a free area opening of one square inch per 4,000 BTU/HR of heater input rating for each grill. If a horizontal duct is used, a grill free area or duct opening shall have a free area opening of one square inch per 2,000 BTU/HR for each grill. Follow the *National Fuel Code NFPA 54/ANSI Z223.1, Section 5.3 Air for Combustion and Ventilation* for required size of ventilation grills or ducts.

IMPORTANT: Do not provide openings for inlet or outlet air into attic if attic has a thermostat-controlled power vent. Heated air entering the attic will activate the power vent.

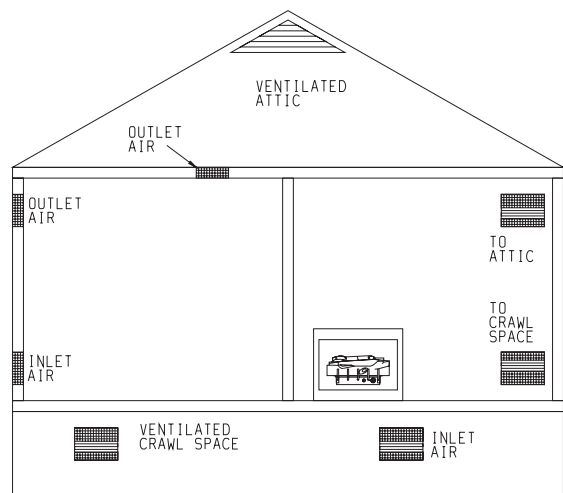

Figure 2

GAS SUPPLY

Check all local codes for requirements, especially for the size and type of gas supply line required.

Recommended Gas Pipe Diameter

Pipe Length	Schedule 40 Pipe Inside Diameter		Tubing, Type L Outside Diameter	
	Nat.	L.P.	Nat.	L.P.
0-10 feet 0-3 meters	1/2" 12.7mm	3/8" 9.5mm	1/2" 12.7mm	3/8" 9.5mm
10-40 feet 4-12 meters	1/2" 12.7mm	1/2" 12.7mm	5/8" 15.9mm	1/2" 12.7mm
40-100 feet 13-30 meters	1/2" 12.7mm	1/2" 12.7mm	3/4" 19mm	1/2" 12.7mm
100-150 feet 31-46 meters	3/4" 19mm	1/2" 12.7mm	7/8" 22.2mm	3/4" 19mm

NOTICE: Never use plastic pipe. Check to confirm whether your local codes allow copper tubing or galvanized.

NOTICE: Since some municipalities have additional local codes, it is always best to consult your local authority and installation code.

Installing a New Main Gas Cock

Each appliance should have its own manual gas cock.

A manual main gas cock should be located in the vicinity of the unit. Where none exists, or where its size or location is not adequate, contact your local authorized installer for installation or relocation. Compounds used on threaded joints of gas piping shall be resistant to the action of liquefied petroleum gases. The gas lines must be checked for leaks by the installer. This should be done with a soap solution watching for bubbles on all exposed connections, and if unexposed, a pressure test should be made.

Never use an exposed flame to check for leaks. Appliance must be disconnected from piping at inlet of control valve and pipe capped or plugged for pressure test. Never pressure test with appliance connected; control valve will sustain damage!

A gas valve and ground joint union should be installed in the gas line upstream of the gas control to aid in servicing. It is required by the National Fuel Gas Code that a drip line be installed near the gas inlet. This should consist of a vertical length of pipe tee connected into the gas line that is capped on the bottom in which condensation and foreign particles may collect.

The use of the following gas connectors is recommended:

- ANS Z21.24 Appliance Connectors of Corrugated Metal Tubing and Fittings
- ANS Z21.45 Assembled Flexible Appliance Connectors of Other Than All-Metal Construction

The above connectors may be used if acceptable by the authority having jurisdiction. The state of Massachusetts requires that a flexible appliance connector cannot exceed three feet in length.

Pressure Testing of the Gas Supply System

1. To check the inlet pressure to the gas valve, a 1/8" (3mm) N.P.T. plugged tapping, accessible for test gauge connection, must be placed immediately upstream of the gas supply connection to the appliance.
2. The appliance and its individual shutoff valve must be disconnected from the gas supply piping system during any pressure testing of that system at test pressures in excess of 1/2 psig (3.5 kPa).

3. The appliance must be isolated from the gas supply piping system by closing its individual manual shutoff valve during any pressure testing of the gas supply piping system at test pressures equal to or less than 1/2 psig (3.5 kPa).

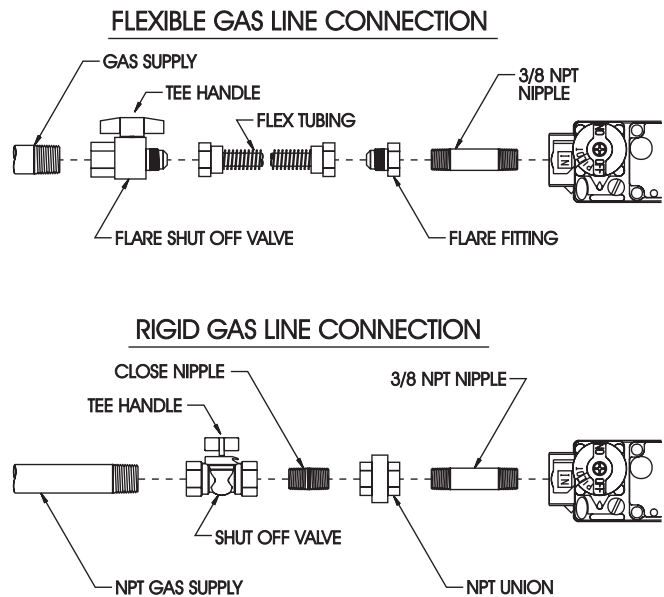

Figure 3

Attention! If one of the above procedures results in pressures in excess of 1/2 psig (14" w.c.) (3.5 kPa) on the appliance gas valve, it will result in a hazardous condition.

Checking Manifold Pressure

Millivolt Models Natural gas will have a manifold pressure of approximately 3.5" w.c. (.871kPa) for maximum input or 1.7" w.c. (.423kPa) for minimum input at the pressure regulator outlet with the inlet pressure to the pressure regulator from a minimum of 5.0" w.c. (1.120kPa) for the purpose of input adjustment to a maximum of 10.5" w.c. (2.614kPa).

Hydraulic Thermostat Models Natural gas will have a manifold pressure of approximately 6.0" w.c. (1.49kPa) at the pressure regulator outlet with the inlet pressure to the pressure regulator from a minimum of 7.0" w.c. (1.74kPa) for the purpose of input adjustment to a maximum of 10.5" w.c. (2.615kPa).

Millivolt Models Propane gas will have a manifold pressure approximately 10.0" w.c. (2.49kPa) for maximum input or 6.3" w.c. (1.568kPa) for minimum input at the pressure regulator outlet with the inlet pressure to the pressure regulator from a minimum of 11.0" w.c. (2.739kPa) for the purpose of input adjustment to a maximum of 13.0" w.c. (3.237kPa).

Hydraulic Thermostat Models Propane gas will have a manifold pressure approximately 10.0" w.c. (2.49kPa) at the pressure regulator outlet with the inlet pressure to the pressure regulator from a minimum of 11.0" w.c. (2.739kPa) for the purpose of input adjustment to a maximum of 13.0" w.c. (3.237kPa).

CLEARANCES

Minimum Wall and Ceiling Clearances

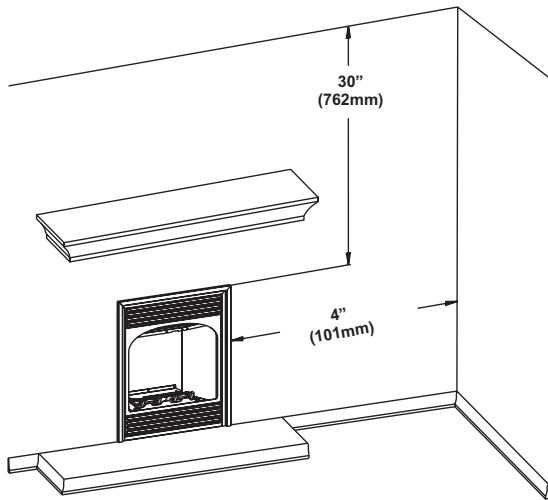

Figure 4

This fireplace can be installed with zero (0") clearance to combustible material.

When facing the front of the appliance the minimum clearances to combustible construction (material) are the following:

1. Clearances from the right side or left side of the fireplace opening to any combustible wall or material should not be less than 4 inches.
2. Clearances from the top of the fireplace opening to the ceiling should not be less than 30 inches.

Mantel Clearances for Built-in Installation

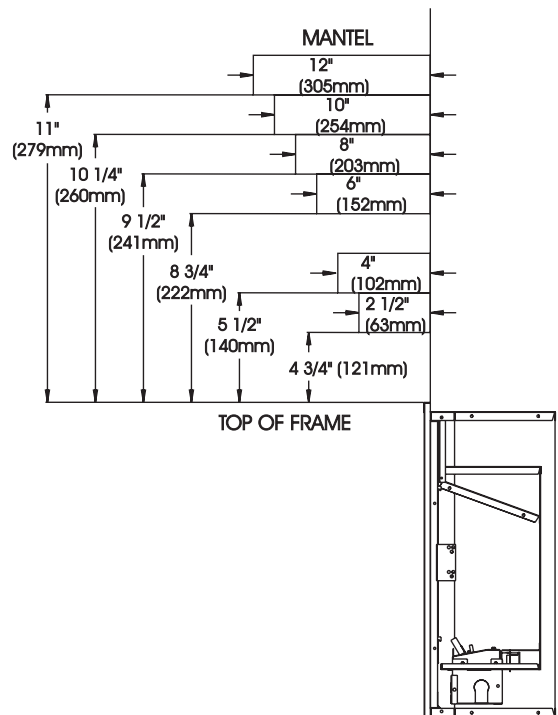

Figure 5

COMBUSTIBLE MATERIAL

Do not attach combustible material to the mantel of your fireplace. This is a fire hazard.

No greeting cards, stockings or ornamentation of any type should be placed on or attached to the fireplace. This is a heating appliance. The flow of heat can ignite combustibles.

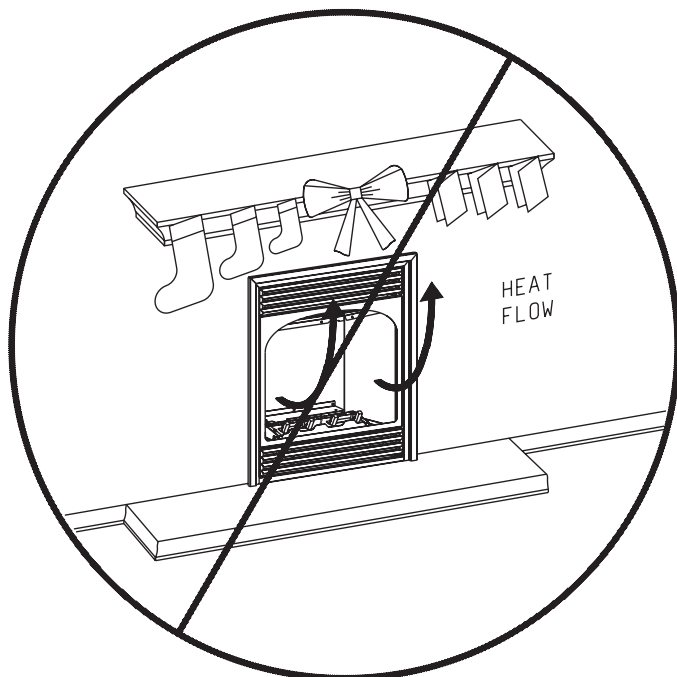

Figure 6

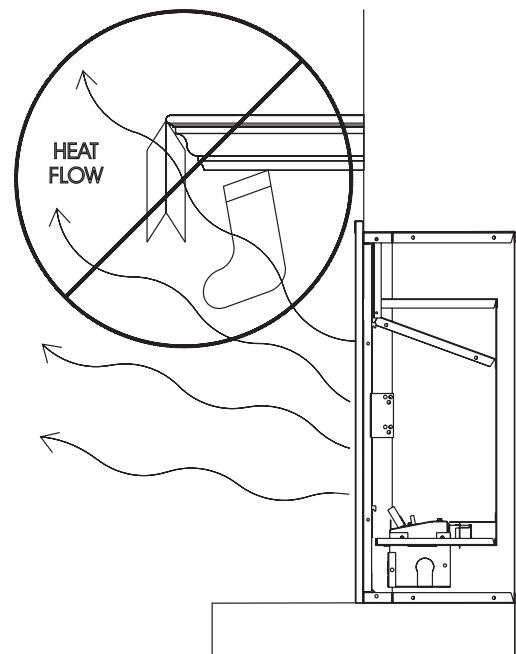

Figure 7

INSTALLATION OF FIREPLACE INTO MANTEL

1. Position base approximately 5" from wall surface.
2. Attach nailing flange to fireplace top with two (2) 10 x 1/2" screws.
3. Place fireplace on top of base.
4. Gas line connections must be made at this time. When facing the fireplace the gas supply will enter on right-hand side. See "Gas Supply" Page 8.
5. Place right mantel side against base. Insert dowels in breastboard into right mantel side. Breastboard will rest on fireplace top and in front of nailing flange.
Attention: Placing the breastboard in front of nailing flange will secure the fireplace.
6. Place left mantel side against base. Insert dowels in breastboard into left mantel side.
7. Use four (4) pre-drilled screw holes on back of breastboard to secure breastboard to mantel sides with four (4) Phillips wood screws.
8. Place mantel top onto mantel.
9. Installation of fireplace into mantel is completed.

Installation of Trim

1. Lower bottom louver.
2. Remove screen from fireplace.
3. Remove top louver from fireplace [two (2) Phillips screws].
4. Attach right and lift trim to fireplace. Use two (2) Phillips screws for each side.
5. Attach trim top to fireplace with two (2) Phillips screws.
6. Reattach top louver to fireplace using two (2) Phillips screws.
7. Reattach screen to fireplace.
8. Raise bottom louver.

Installing Fireplace in Mantel

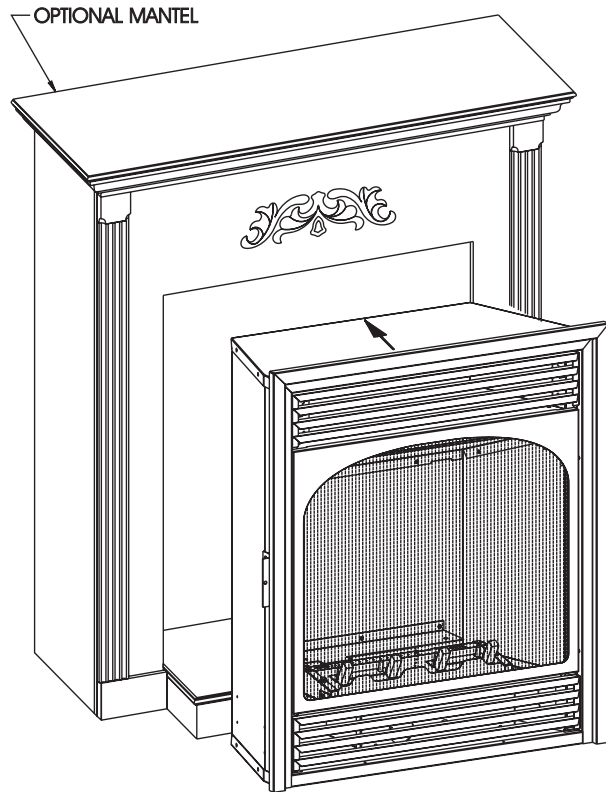

Figure 9

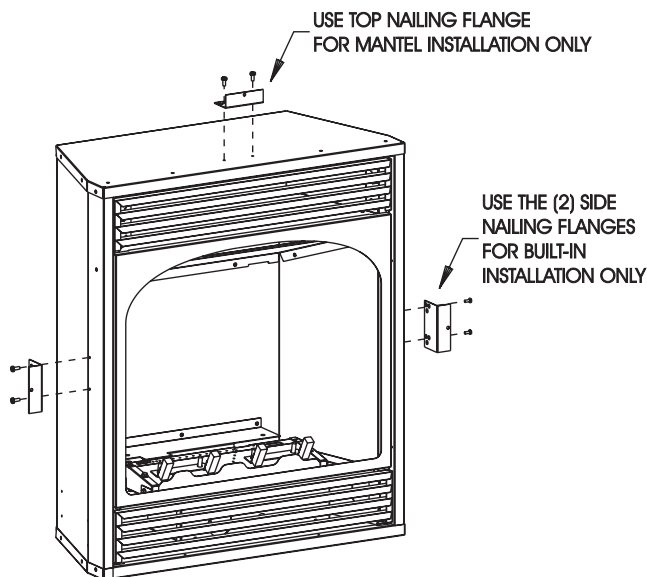

Figure 8

BUILT-IN FIREPLACE INSTALLATION

Built-In Fireplace Installation

Built-in installation of this fireplace involves installing fireplace into a framed-in enclosure. This makes the front of fireplace flush with wall. If installing a mantel above the fireplace, you must follow the clearances shown in Figure 5, page 9. Follow the instructions below to install the fireplace in this manner.

Frame in rough opening. Use dimensions shown in Figure 10 for a conventional rough opening. Use dimensions shown in Figure 11 for corner rough opening. Be sure to provide gas line for fireplace and electrical power for FBB6 optional blower assembly.

1. Attach two (2) nailing flanges to firebox sides with two (2) 10 x 1/2" screws for each nailing flange.
2. Gas line connections must be made at this time. When facing the appliance the gas supply will enter on right-hand side. See "Gas Supply" Page 8.
3. Insert fireplace into enclosure.
4. Attach nailing flanges to framing with a screw or nail.
5. Finished wall surface will be flush to the leading edge of fireplace top and sides.
6. Installation of built-in fireplace is completed.

Installation of Trim

1. Lower bottom louver.
2. Remove screen from fireplace.
3. Remove top louver from fireplace [two (2) Phillips screws].
4. Attach right and lift trim to fireplace. Use two (2) Phillips screws for each side.
5. Attach trim top to fireplace with two (2) Phillips screws.
6. Reattach top louver to fireplace using two (2) Phillips screws.
7. Reattach screen to fireplace.
8. Raise bottom louver.

Rough Opening for Installing in Corner

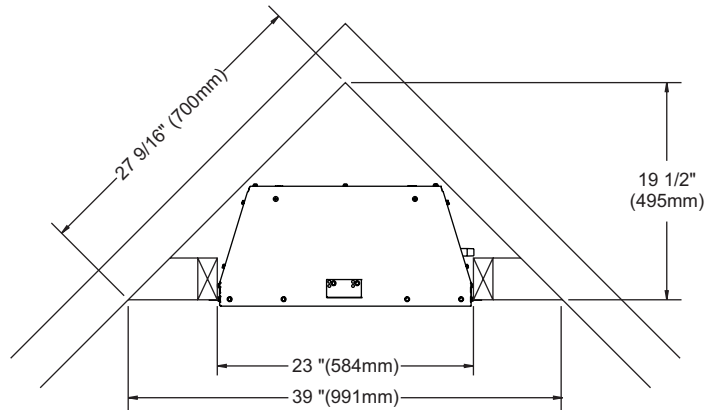

Figure 11

Rough Opening for Installing in Wall

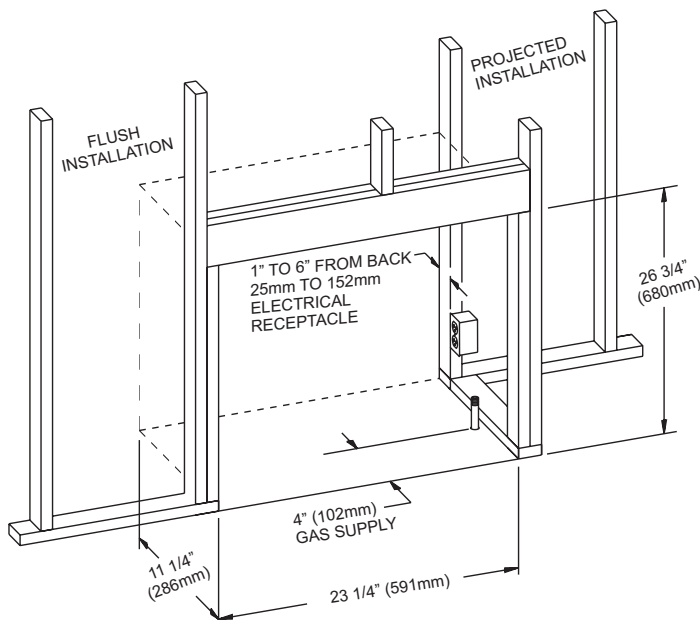

Figure 10

USE TOP NAILING FLANGE FOR MANTEL INSTALLATION ONLY

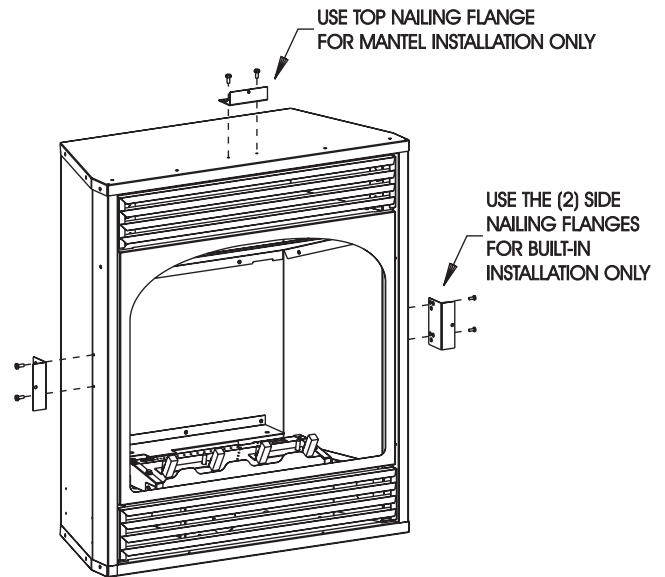

Figure 12

PLACEMENT OF GLOWING EMBERS (ROCK WOOL)

Provided with the log set is a small bag of glowing embers (rock wool) to be placed between logs on the flat metal surface of the burner.

Placement of the embers (rock wool) is very individual and light coverage of the areas indicated will provide your best effects. We recommend separation of the rock wool by hand and make your coverage as light and fluffy as possible.

Place just enough embers (rock wool) on the burner to obtain the glow and a gold yellow flame.

Do not place rock wool over large ports in rear portion of burner.

A thin layer of rock wool should be placed under open space between the right and left middle logs.

Rock wool should **not** be placed in the area of the pilot assembly.

Replacement of loose material (glowing embers) must be purchased from Empire Comfort Systems, Inc. Application of excess loose material (glowing embers) may adversely affect performance of the heater.

WARNING

All previously applied loose material must be removed prior to reapplication.

Refer to Parts List, Page 19 to order loose material (rock wool).

Replacement Loose Material (Glowing Embers)

15998	Supplied Rock Wool
PE-20-1	Optional Platinum Bright Embers Kit

NOTICE: A single layer of embers is to be used when applying Platinum Bright Embers (alone or in combination with production embers) to the burner.

OPERATION INSTRUCTIONS/FLAME APPEARANCE

Flames from the pilot (rear right back side of the pan burner) as well as the main flame should be visually checked as the log set is installed.

In normal operation at full rate after 10 to 15 minutes, the flame appearance should be sets of yellow flames.

NOTICE: all flames will be random by design, flame height will go up and down.

Glowing embers (rock wool) can cover the pan burner in between the front and middle logs, but very little is necessary to cover this area. Excess ember material causes the yellow flame to become orange and stringy. Apply just enough to obtain slow glow and a gold, yellow flame.

Avoid any drafts that alter burner flame patterns. Do not allow fans to blow directly into fireplace. Do not place a blower inside the burner area of the firebox. Ceiling fans may create drafts that alter flame patterns. Sooting and improper burning will result.

During manufacturing, fabricating and shipping, various components of this appliance are treated with certain oils, films or bonding agents. These chemicals are not harmful, but may produce annoying smoke and smells as they are burned off during the initial operation of the appliance, possibly causing headaches or eye or lung irritation. This is a normal and temporary occurrence.

The initial break-in operation should last 2-3 hours with the burner at the highest setting. Provide maximum ventilation by opening windows or doors to allow odors to dissipate. Any odors remaining after this initial break-in will be slight and will disappear with continued use.

This appliance must not be used with glass doors in the closed position. This can lead to pilot outages and severe sooting outside the fireplace.



MILLIVOLT CONTROLS LIGHTING INSTRUCTIONS

FOR YOUR SAFETY READ BEFORE LIGHTING

⚠ WARNING: If you do not follow these instructions exactly, a fire or explosion may result causing property damage, personal injury or loss of life.

- A. This appliance has a pilot which must be lighted by hand. When lighting the pilot, follow these instructions exactly.
- B. **BEFORE LIGHTING** smell all around the appliance area for gas. Be sure to smell next to the floor because some gas is heavier than air and will settle on the floor.
WHAT TO DO IF YOU SMELL GAS
 - Do not try to light any appliance.
 - Do not touch any electrical switch; do not use any phone in your building.
 - Immediately call your gas supplier from a neighbor's phone. Follow the gas supplier's instructions.
 - If you cannot reach your gas supplier, call the fire department.
- C. Use only your hand to push in or turn the gas control knob. Never use tools. If the knob will not push in or turn by hand, don't try to repair it; call a qualified service technician. Force or attempted repair may result in a fire or explosion.
- D. Do not use this appliance if any part has been under water. Immediately call a qualified service technician to inspect the appliance and to replace any part of the control system and any gas control which has been under water.

LIGHTING INSTRUCTIONS

1. STOP! Read the safety information label.
2. Open bottom louver assembly.
3. Set REMOTE/OFF/ON switch to "OFF."
4. Turn off all electric power to the appliance (if applicable).
5. Push in gas control knob slightly and turn clockwise  to "OFF." NOTE: Knob cannot be turned from "PILOT" to "OFF" unless knob is pushed in slightly. Do not force.
6. Wait ten (10) minutes to clear out any gas. Then smell for gas, including near the floor. If you smell gas, STOP! Follow "B" in the safety information above. If you do not smell gas, go to the next step.
7. Find pilot - Follow metal tube from gas control. The pilot is behind the burner on the right side.
8. Turn gas control knob counterclockwise  to "PILOT."
9. Push in control knob all the way and hold in. Repeatedly push the Piezo Ignitor Button until the pilot is lit. Continue to hold the control knob in for about one (1) minute after the pilot is lit. Release knob, and it will pop back up. Pilot should remain lit. If it goes out, repeat steps 5 through 9.
 - If knob does not pop up when released, STOP and IMMEDIATELY call a qualified service technician or gas supplier.
 - If the pilot will not stay lit after several tries, turn the gas control knob to "OFF" and call your service technician or gas supplier.
10. Turn gas control knob counterclockwise  to "ON."
11. Set REMOTE/OFF/ON switch to desired setting.
12. Turn on all electric power to the appliance (if applicable).
13. Close bottom louver assembly.

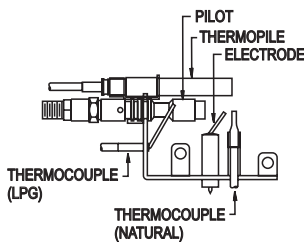
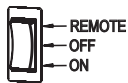
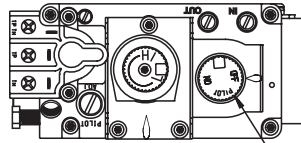

TO TURN OFF GAS TO APPLIANCE

1. Open bottom louver assembly (if applicable).
2. Set REMOTE/OFF/ON switch to OFF.
3. Turn off all electric power to the appliance if service is to be performed (if applicable).
4. Push in gas control knob slightly and turn clockwise  to "OFF." Do not force.
5. Close bottom louver assembly (if applicable).

HYDRAULIC THERMOSTAT MODELS LIGHTING INSTRUCTIONS

FOR YOUR SAFETY READ BEFORE LIGHTING

⚠ WARNING: If you do not follow these instructions exactly, a fire or explosion may result causing property damage, personal injury or loss of life.

- A. This appliance has a pilot which must be lighted by hand. When lighting the pilot, follow these instructions exactly.
- B. **BEFORE LIGHTING** smell all around the appliance area for gas. Be sure to smell next to the floor because some gas is heavier than air and will settle on the floor.
- WHAT TO DO IF YOU SMELL GAS**
- Do not try to light any appliance.
 - Do not touch any electrical switch; Do not use any phone in your building.
 - Immediately call your gas supplier from a neighbor's phone. Follow the gas supplier's instructions.
 - If you cannot reach your gas supplier, call the fire department.
- C. Use only your hand to push in or turn the gas control knob. Never use tools. If the knob will not push in or turn by hand, don't try to repair it; call a qualified service technician. Force or attempted repair may result in a fire or explosion.
- D. Do not use this appliance if any part has been under water. Immediately call a qualified service technician to inspect the appliance and to replace any part of the control system and any gas control which has been under water.

LIGHTING INSTRUCTIONS

1. STOP! Read the safety information above.
2. Set thermostat (gas control knob) to lowest setting.
3. Turn off all electric power to the appliance (if applicable).
4. Push in gas control knob slightly and turn clockwise  to "OFF." Do not force.

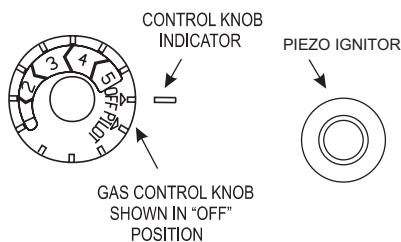

5. Wait ten (10) minutes to clear out any gas. Then smell for gas, including near floor. If you smell gas, STOP! Follow "B" in the safety information on other side. If you do not smell gas, Go to the Next step.
6. Find pilot - the pilot is located in front of rear log.

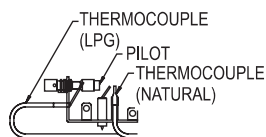

7. Turn manual gas control knob counterclockwise  to "PILOT."

8. Push in manual gas control knob all the way and hold in. Repeatedly push the piezo ignitor button until pilot is lit (or use a match to light). Continue to hold the control knob in for about one (1) minute after the pilot is lit. Release knob and it will pop back up. Pilot should remain lit. If it goes out, repeat steps 4 through 8.
 - If knob does not pop up when released, stop and immediately call a qualified service technician or gas supplier.
 - If the pilot will not stay lit after several tries, turn the gas control knob to "OFF" and call a qualified service technician or gas supplier.
9. Attention! Gas control has an INTERLOCK latching device. When the pilot is initially lit and the safety magnet is energized (pilot stays "ON") the INTERLOCK latching device becomes operative. If the gas control is turned to the "OFF" position or gas flow to the appliance is shut off, the pilot cannot be re-lighted until the safety magnet is de-energized (approximately 60 seconds). There will be an audible "click" when the safety magnet in the gas control is de-energized. Pilot can now be re-lighted. Repeat steps 4 through 8.
10. Turn the gas control knob counterclockwise  to "HIGH (5)."
11. Turn on all electric power to the appliance (if applicable).
12. Set the thermostat (gas control knob to desired setting from "HIGH (5)" to "LOW (1)."

TO TURN OFF GAS TO APPLIANCE

1. Set thermostat (gas control knob) to lowest setting.
2. Turn off all electric power to appliance if service is to be performed (if applicable).
3. Push in gas control knob slightly and turn clockwise  to "OFF". Do not force.

PILOT FLAME CHARACTERISTICS

Figures 13 and 15 show a correct pilot flame pattern. The correct flame will be blue and will extend beyond the thermocouple. The flame will surround the thermocouple just below the tip. A slight yellow flame may occur where the pilot flame and main burner flame meet. Figures 14 and 16 show an incorrect pilot flame pattern. The incorrect pilot flame is not touching the thermocouple. This will cause the thermocouple to cool. When the thermocouple cools, the heater will shut down.

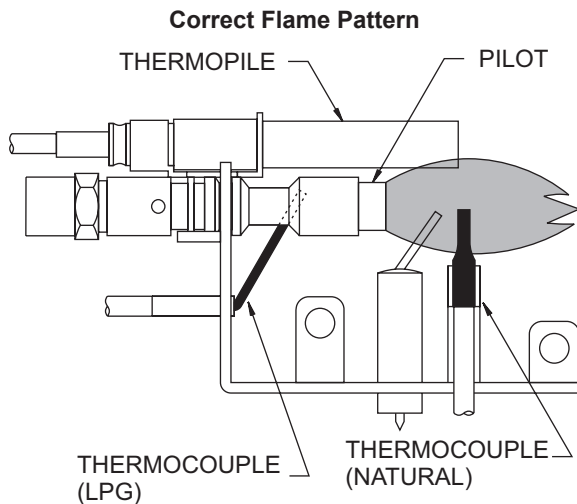

**Millivolt Pilot
Figure 13**

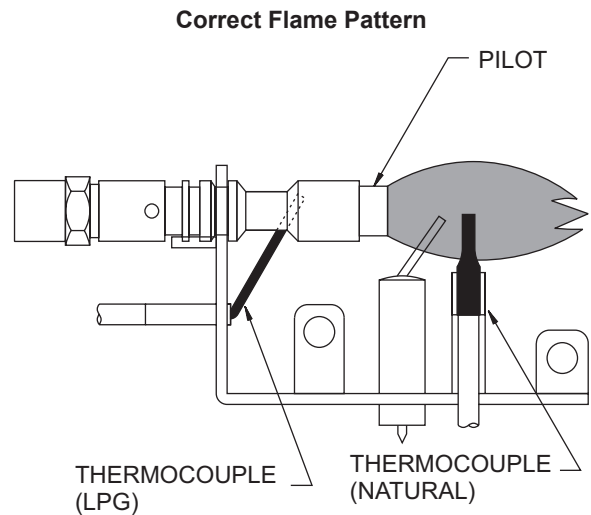

**Hydraulic Thermostat Pilot
Figure 15**

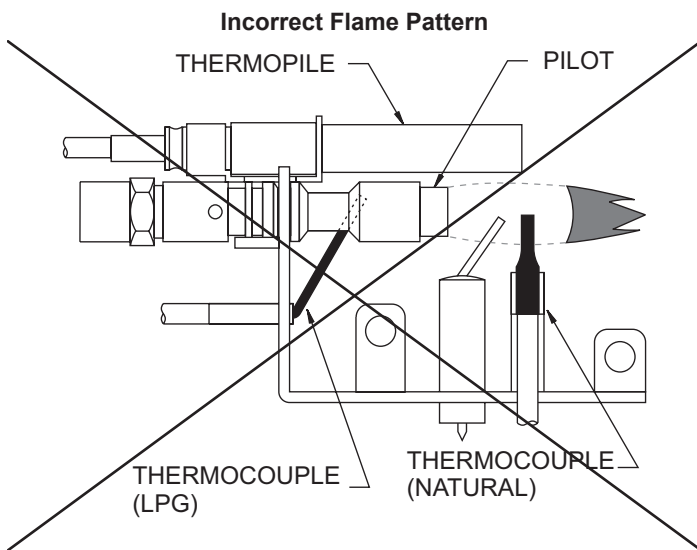

**Millivolt Pilot
Figure 14**

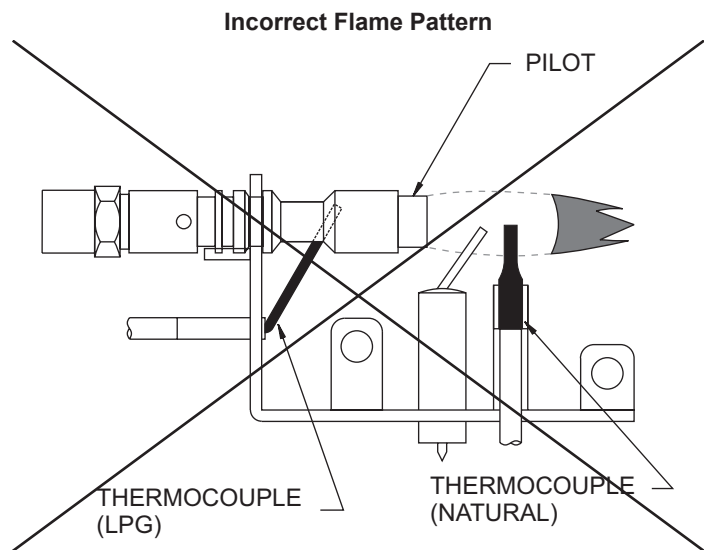

**Hydraulic Thermostat Pilot
Figure 16**

If pilot flame pattern is incorrect as shown in Figures 14 and 16:

- See Troubleshooting, Page 18

PILOT FLAME CHARACTERISTICS

Cleaning and Maintenance/Pilot

Oxygen Depletion Sensor Pilot (Figures 17 and 18)

When the pilot has a large yellow tip flame, clean the Oxygen Depletion Sensor as follows:

1. Clean the ODS pilot by loosening nut B from the pilot tubing. When this procedure is required, grasp nut A with an open end wrench.
2. Blow air pressure through the holes indicated by the arrows. This will blow out foreign materials such as dust, lint and spider webs. Tighten nut B also by grasping nut A.

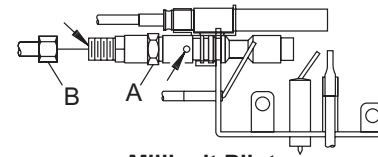

Millivolt Pilot
Figure 17

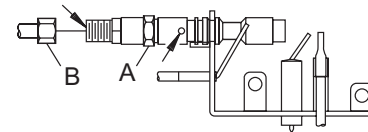

Hydraulic Thermostat
Figure 18

⚠ WARNING

Never use needles, wires, or similar cylindrical objects to clean the pilot to avoid damaging the calibrated ruby that controls the gas flow.

MAIN BURNER AND THERMOSTAT OPERATION

The VFP24FP2 Series gas control maximum and minimum inputs are listed below.

OFF is the OFF position.

PILOT is the PILOT position.

VFP24FP2 Series

Max. 20,000 BTU/HR

Min. 10,000 BTU/HR

VFP24FP3 Series Main Burner Operation

The gas control modulates from a minimum input of 14,000 BTU/HR (LO setting) to a maximum input of 20,000 BTU/HR (HI setting).

VFP24FP3 Series (with 10,000 BTU burner)

Fixed 10,000 BTU/HR

Cleaning and Maintenance / Main Burner

⚠ WARNING

Turn off heater and let cool before cleaning.

⚠ CAUTION

You must keep control areas, burner and circulating air passageways of heater clean. Inspect these areas of heater before each use. Have heater inspected yearly by a qualified service person. Heater may need more frequent cleaning due to excessive lint from carpeting, bedding materials, etc.

Logs

Be careful cleaning and handling logs so as not to damage them. If logs break or fall apart in handling, spray the broken pieces and fibers with water, sweep up and discard.

WIRING

Label all wires prior to disconnection when servicing controls. Wiring errors can cause improper and dangerous operation. Verify proper operation after servicing.

Millivolt thermopile is self powered, gas valve does not require 110 volts. Maximum length of 20 feet of 16 AWG to conductor wires is to be used with all optional switches.

Use the two leads (Red and Green) to attach optional components.

Check 750 Millivolt System Operation

Millivolt system and all individual components may be checked with a millivolt meter 0-1000 MV range.

Remote Receiver

Use the following steps to place the remote receiver adjacent to the gas valve.

Attention: The remote receiver bracket is not used in this installation.

1. The remote receiver can not be placed behind the gas valve and burner assembly.
2. When facing the appliance, the remote receiver must be placed to the right of the gas valve.

Install remote control receiver behind bottom louver.

Refer to remote control installation and operating instructions for more details on remote control.

WIRING DIAGRAM

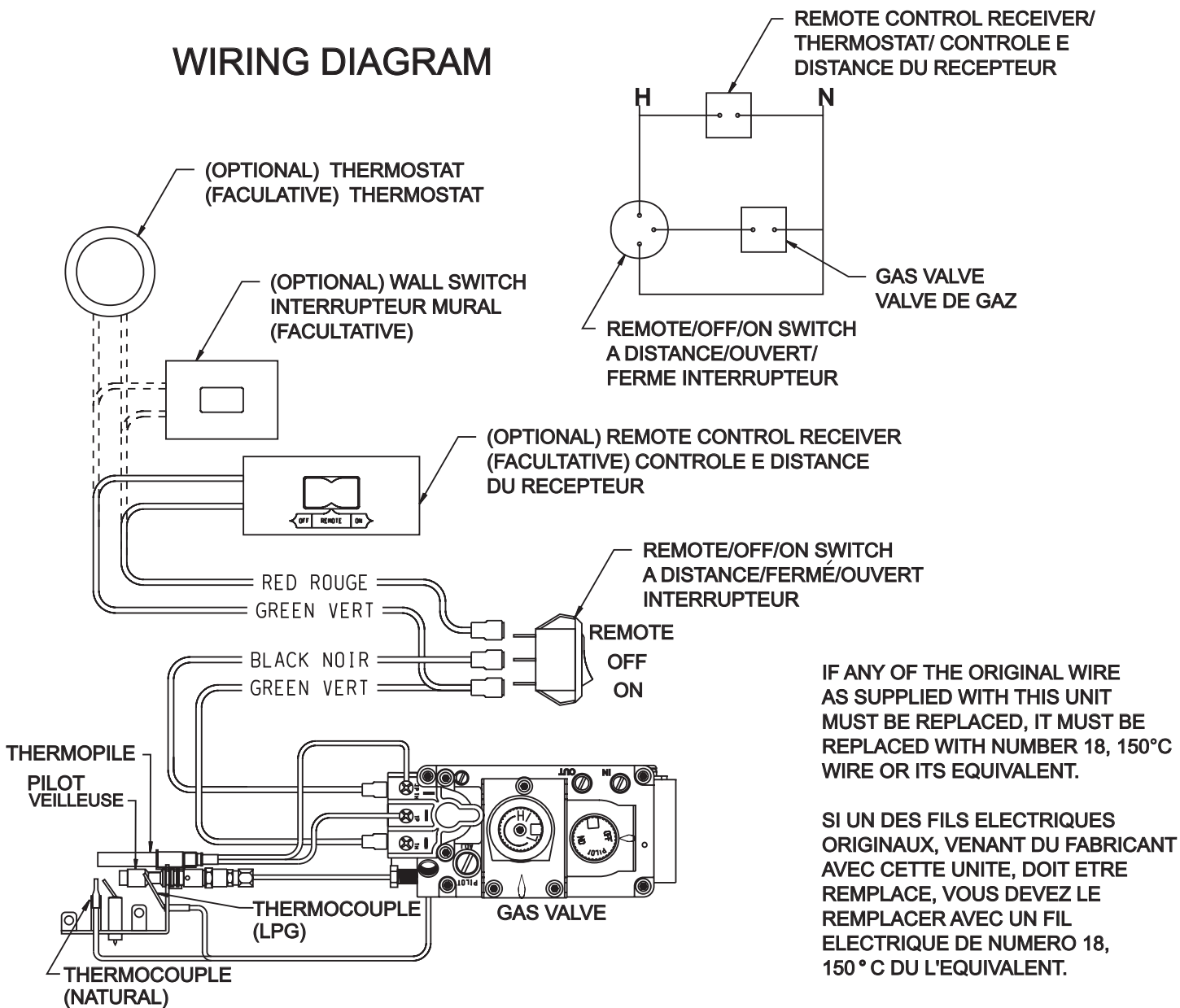

Millivolt Models
Wiring Diagram
Figure 19

TROUBLESHOOTING

SYMPTOMS, POSSIBLE CAUSES AND CORRECTIONS

Turn appliance OFF and allow to cool before servicing. Only a qualified service person should service and repair the heater.

- 1. When ignitor button is pressed, there is no spark at ODS/pilot.**
 - a. Ignitor electrode positioned wrong - Replace pilot.
 - b. Ignitor electrode is broken - Replace pilot.
 - c. Ignitor electrode not connected to ignitor cable - Reconnect ignitor cable.
 - d. Ignitor cable pinched or wet. Keep ignitor cable dry - Free ignitor cable if pinched by any metal or tubing.
 - e. Broken ignitor cable - Replace ignitor cable.
 - f. Bad piezo ignitor - Replace piezo ignitor.
- 2. Appliance produces unwanted odors.**
 - a. Appliance burning vapors from paint, hair spray, glues, etc. - Ventilate room. Stop using odor causing products while heater is running.
 - b. Gas leak - Locate and correct all leaks.
- 3. Appliance shuts off during use. (Pilot and main burner are off.)**
 - a. Not enough fresh air is available for ODS/pilot to operate - Open window and/or door for ventilation.
 - b. Low line pressure - Contact local gas company.
 - c. ODS/pilot is partially clogged - Clean ODS/pilot.
 - d. Defective thermocouple - Replace pilot.
- 4. Appliance shuts off during use. (Pilot stays on.)**
 - a. Low line pressure - Check line pressure to the valve.
 - b. Defective thermopile - Check pilot flame, check wire connections, output should be a minimum of 325 millivolts across. TH/TP and TP terminals with ON/OFF switch off.
- 5. Gas odor even when control knob is in OFF position.**
 - a. Gas leak - Locate and correct all leaks.
 - b. Control valve defective - Replace control valve.
- 6. When ignitor button is pressed, there is spark at ODS/pilot, but no ignition.**
 - a. Gas supply turned off or manual shutoff valve closed - Turn on gas supply or open manual shutoff valve.
 - b. Control knob not in PILOT position - Turn control knob to PILOT position.
 - c. Control knob not pressed in while in PILOT position - Press in control knob while in PILOT position.
 - d. Air in gas lines when installed - Continue holding down control knob. Repeat igniting operation until air is removed.
 - e. ODS/pilot is clogged - Replace ODS/pilot assembly or get it serviced.
 - f. Gas regulator setting is not correct - Replace gas regulator.
- 7. ODS/pilot lights but flame goes out when control knob is released.**
 - a. Control knob not fully pressed in - Press in control knob fully.
 - b. Control knob not pressed in long enough - After ODS/pilot lights, keep control knob pressed in 30 seconds.
- c. Manual Shutoff valve not fully open - Fully open manual shutoff valve.
 - d. Thermocouple connection loose at control valve - Hand tighten until snug, then tighten 1/4 turn more.
 - e. Pilot flame not touching thermocouple, which allows thermocouple to cool, causing pilot flame to go out. This problem could be caused by either low gas pressure or dirty or partially clogged ODS/pilot - Contact local gas company.
 - f. Thermocouple damaged - Replace thermocouple.
 - g. Control valve damaged - Replace control valve.
- 8. Burner does not light after ODS/pilot is lit.**
 - a. Burner orifice clogged - Clean burner or replace main burner orifice.
 - b. Burner orifice diameter is too small - Replace burner orifice.
 - c. Inlet gas pressure is too low - Contact qualified service person.
- 9. If burning at main burner orifice occurs (a loud, roaring blow torch noise).**
 - a. You must turn off burner assembly and contact a qualified service person.
 - b. Manifold pressure is too low - Contact local gas company.
 - c. Burner orifice clogged - Clean burner or replace burner orifice.
- 10. Logs appear to smoke after initial operation.**
 - a. Vapors from paint or curing process of logs - Problem will stop after a few hours of operation. Run the heater with the damper open if you have one, or open a window for the first few hours.
Log heater is intended to be smokeless. Turn OFF heater and call qualified service person.
- 11. Heater produces a whistling noise when main burner is lit.**
 - a. Turning control knob to HIGH position when main burner is cold - Turn control knob to LOW position and let warm up for a minute.
 - b. Air in gas line - Operate burner until air is removed from line. Have gas line checked by local gas company.
 - c. Dirty or partially clogged burner orifice - Clean burner or replace burner orifice.
- 12. No gas to pilot.**
 - a. LP-regulator shut down due to inlet pressure too high - Verify LP tank regulator is installed and set at 11" to 13" w.c. Replace regulator on heater.

If the gas quality is bad, your pilot may not stay lit, the burners may produce soot and the heater may backfire when lit. If the gas quality or pressure is low, contact your local gas supplier immediately.

PARTS LIST

ATTENTION: When ordering parts, it is very important that **part number** and **description** of part coincide.

INDEX NO.	PART NO.	DESCRIPTION
COMMON		
1	25897	TRIM - TOP
2	25895	TRIM - LEFT
3	25896	TRIM - RIGHT
4	10554	NAILING FLANGE (2 REQUIRED)
5	20447	BRICK LINER BRACKET - UPPER (2 REQUIRED)*
6	R6498	BRICK PANEL - REAR*
7	R6497	BRICK PANEL SIDE - LEFT*
8	R6499	BRICK PANEL SIDE - RIGHT*
9	19401	BRICK LINER BRACKET -LOWER (2 REQUIRED)*
10	25774	LOUVER ASSEMBLY - UPPER
11	25777	SCREEN ASSEMBLY (INCLUDES 12 & 13)
12	25779	BRACKET, SCREEN RETAINER (2 REQUIRED)
13	R10364	SCREEN, CURTAIN
14	25775	LOUVER ASSEMBLY - LOWER
15	25781	REAR LOG SUPPORT
16	12348	BURNER ASSEMBLY - LPG
16	12347	BURNER ASSEMBLY - NAT
17	11833	PILOT SHIELD - NAT ONLY
19	R5675	AIR SHUTTER - LPG
19	R5676	AIR SHUTTER - NAT
20	P-182	ORIFICE - LPG (20,000 BTU)
21	P-253	ORIFICE FITTING - ANGLED
22	25785	VALVE / REGULATOR BRACKET
NOT SHOWN	R5668	IGNITOR WIRE
NOT SHOWN	12389	CERAMIC MEDIA (REPAIR)
NOT SHOWN	15998	ROCK WOOL
NOT SHOWN	P-251	COUPLING (NAT ONLY)

* Brick Panels are an optional accessory and not required for use with fireplace.

INDEX NO.	PART NO.	DESCRIPTION
VFP24FP30L and VFP24FP30L10		
18	R3623	PILOT ASSEMBLY - LPG
18	R3624	PILOT ASSEMBLY - NAT
20	P-214	ORIFICE - NAT (10,000 BTU)
20	P-181	ORIFICE - NAT (20,000 BTU)
20	P-193	ORIFICE - LPG (10,000 BTU)
23	R3626	VALVE - NAT (20,000 BTU)
23	R3625	VALVE - LPG (20,000 BTU)
23	R9368	VALVE - NAT (10,000 BTU)
23	R9369	VALVE - LPG (10,000 BTU)
24	R2423	MALE ADAPTOR
25	25787	TUBING (VALVE TO BURNER)
26	25805	TUBING (VALVE TO PILOT) - LPG
26	25788	TUBING (VALVE TO PILOT REGULATOR) - NAT ONLY
27	R7063	PILOT REGULATOR - NAT ONLY
28	25789	TUBING (PILOT REGULATOR TO PILOT) - NAT ONLY
29	P-263	NIPPLE 8"
32	25786	VALVE COVER PLATE
33	R2708	PIEZO IGNITOR
34	R3436	REMOTE/OFF/ON SWITCH
NOT SHOWN	R10947	SWITCH WIRE HARNESS
VFP24FP20L		
18	R5170	PILOT ASSEMBLY - LPG
18	R5171	PILOT ASSEMBLY - NAT
20	P-265	ORIFICE - NAT (20,000 BTU)
23	26012	VALVE - NAT
23	24157	VALVE - LPG
25	24156	TUBING (VALVE TO BURNER)
26	24153	TUBING (VALVE TO PILOT, NAT)
26	24154	TUBING (VALVE TO PILOT, LPG)
29	P-264	NIPPLE 5"
30	R2480	INLET REGULATOR - LPG
30	R2479	INLET REGULATOR - NAT
31	24155	TUBING (REGULATOR TO VALVE)
32	25806	VALVE COVER PLATE
33	R2708	PIEZO IGNITOR
NOT SHOWN	R1720	PLASTIC CLIP

USE ONLY MANUFACTURER'S REPLACEMENT PARTS. USE OF ANY OTHER PARTS COULD CAUSE INJURY OR DEATH.

PARTS VIEW

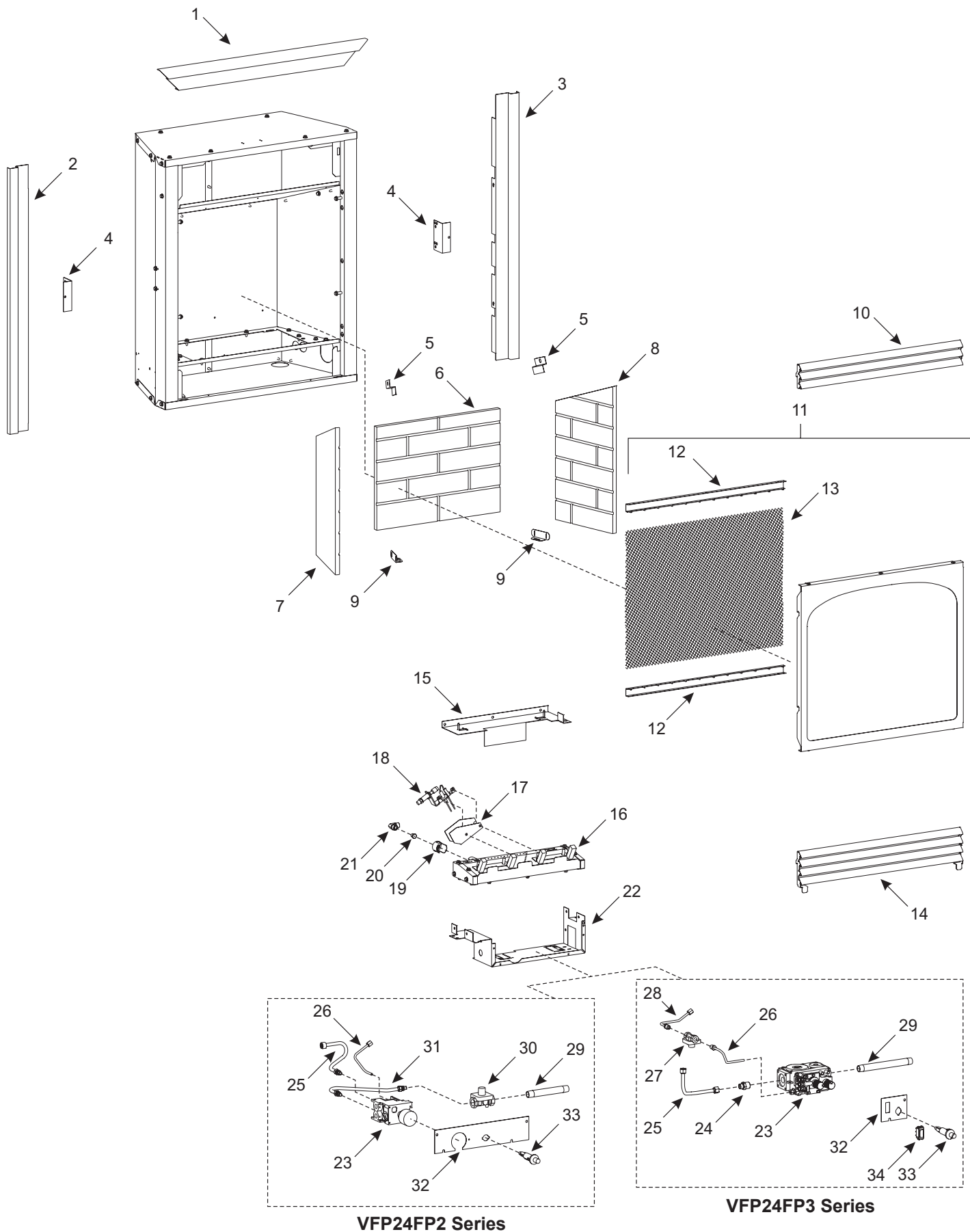

OPTIONAL BRICK LINER INSTALLATION INSTRUCTIONS

VPP1A-22 For Unvented Gas Fireplace

INSTALLING OPTIONAL BRICK LINER

1. Remove screen assembly from fireplace.
 2. Remove logs from burner assembly.
 3. Insert rear brick liner and (2) side brick liners onto bottom of the inner casing. Align grout lines on rear brick liner with grout lines on side brick liners. You must insert rear brick liner before inserting the (2) side brick liners.
 4. Install (1) "Z" shaped brick liner bracket
 5. Install (1) "L" shaped brick liner bracket at the bottom of each side brick liner as illustrated.
- NOTE: Discard the long brick liner mounting brackets not used.
6. Replace logs into burner assembly. Refer to appropriate Installation Instructions and Owner's Manual.
 7. Attach screen assembly to fireplace.
 8. Installation of optional brick liner is completed.

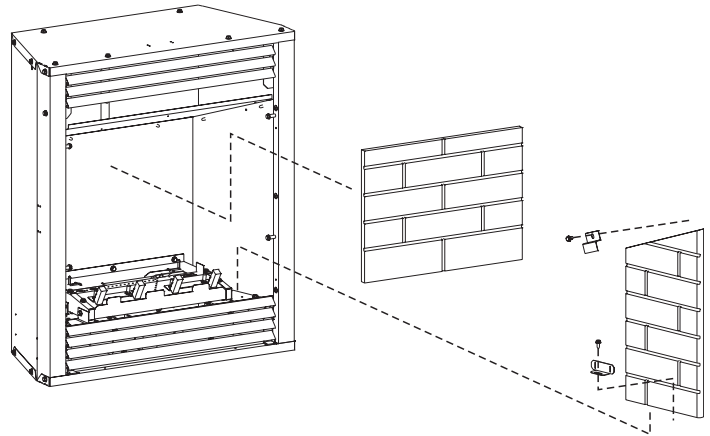
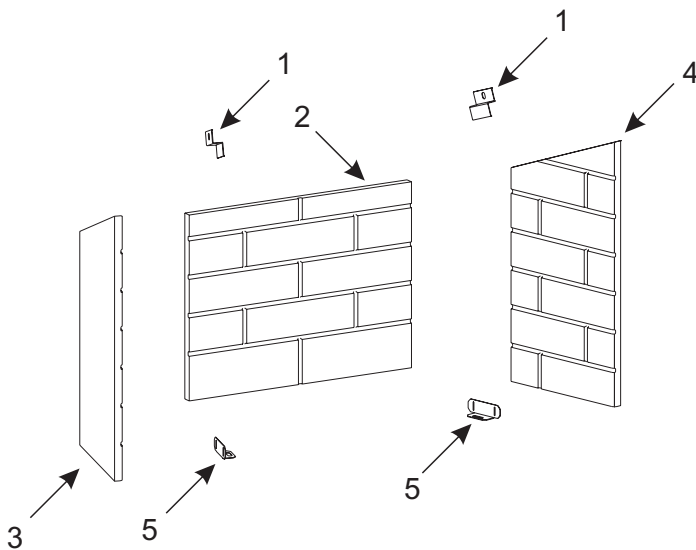

Figure 20



Index Number	Part Number	Description
1	20477	BRICK LINER BRACKET - UPPER (2 REQUIRED)*
2	R6498	BRICK PANEL - REAR*
3	R6497	BRICK PANEL SIDE - LEFT*
4	R6499	BRICK PANEL SIDE - RIGHT*
5	19401	BRICK LINER BRACKET -LOWER (2 REQUIRED)*

OPTIONAL BLOWER INSTALLATION INSTRUCTIONS

FBB6 for Unvented Gas Fireplace Models VFP24FP2 Series & VFP24FP3 Series

INSTALLING OPTIONAL BLOWER

1. Remove bottom louver.
2. Remove upper louver.
3. Remove screen front by lifting upward on screen front.
4. Remove rear log support from inner casing [3 three (3) 10 x 1/2" screws]. See Figure 21.

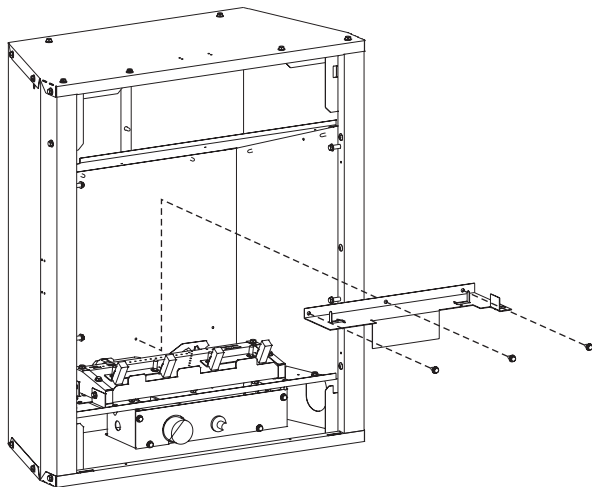

Figure 21

5. Remove burner assembly [four (4) 10 x 1/2" screws]. See Figure 22.

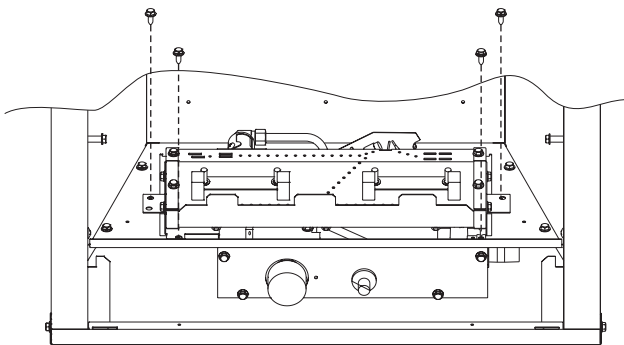

Figure 22

6. Remove two (2) 10 x 1/2" screws on the left side of the firebox bottom. See Figure 23.

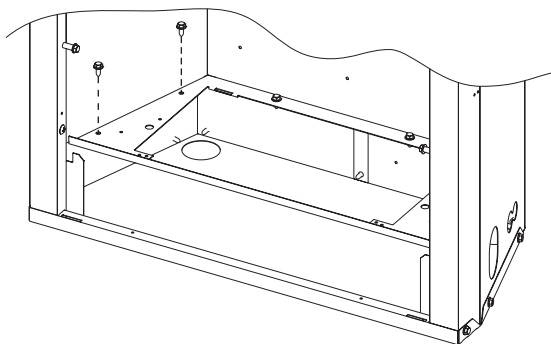

Figure 23

7. Insert blower assembly in left side of outer casing. Motor with wiring will be to the inside of the outer casing, blower chute will be facing upward. See Figure 24.

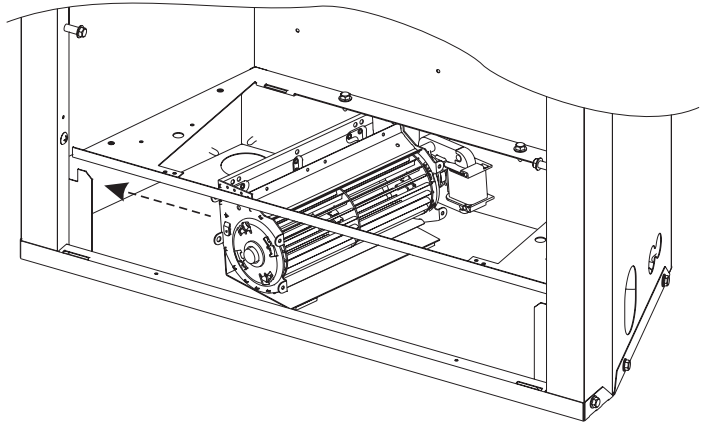
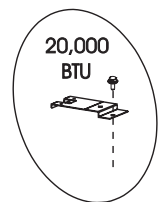

Figure 24

8. Push blower assembly against the left wall of the outer casing. The magnets installed on the bottom of the bracket will hold it in place.
9. Replace the two (2) 10 x 1/2" screws on the left side of the firebox bottom.
10. Attach two (2) flag terminals on wire harness to fan control bracket.
11. Attach fan control bracket to top of inner casing with 10 x 1/2" screw. Refer to Figure 25 for correct position of fan control bracket for 10,000 BTU/hr input or 20,000 BTU/hr input.



OR

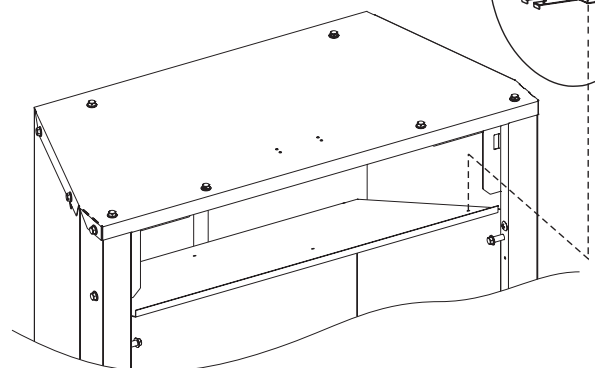
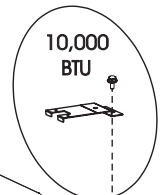

Figure 25

OPTIONAL BLOWER INSTALLATION INSTRUCTIONS

12. Route wires from fan control behind inner casing to bottom of outer casing.
13. Snap Heyco bushing into blower shield side.
14. Place blower shield side adjacent to motor. Route blower motor wires through Heyco bushing on blower shield side. See Figure 26.

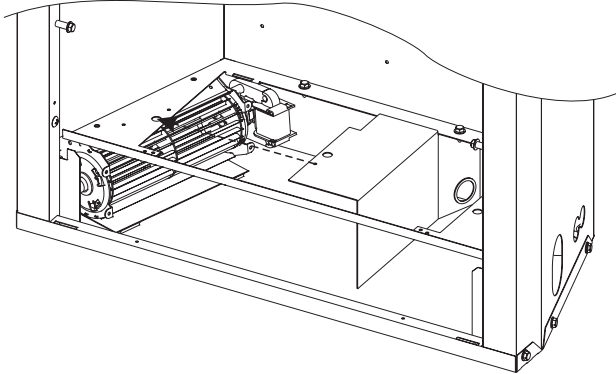

Figure 26

15. Attach black wire from wire harness to OFF terminal on AUTO/OFF/ON switch.
16. Attach white wire from wire harness to ON terminal on AUTO/OFF/ON switch.
17. Attach black/red wire from wire harness to AUTO terminal on AUTO/OFF/ON switch.
18. Route two (2) flag terminals on wire harness through Heyco bushing on blower side shield.
19. Route cord set wires through access hole on right side of outer casing.
20. Insert strain relief in access hole on right side of outer casing.
21. Attach one (1) pin terminal from black (neutral) wire, ribbed insulation on cord set to one (1) socket terminal from black wire on motor.
22. Attach one (1) pin terminal from black (hot) wire, smooth insulation on cord set to (1) socket terminal from black wire on AUOT/OFF/ON.
23. Attach one (1) pin terminal from white wire on AUTO/OFF/ON to switch one (1) socket terminal from white wire on motor.
24. Attach green ground wires from wiring harness and cord set to interior back of outer casing with one (1) 8 x 1/2" Phillips screw. See Figure 27.

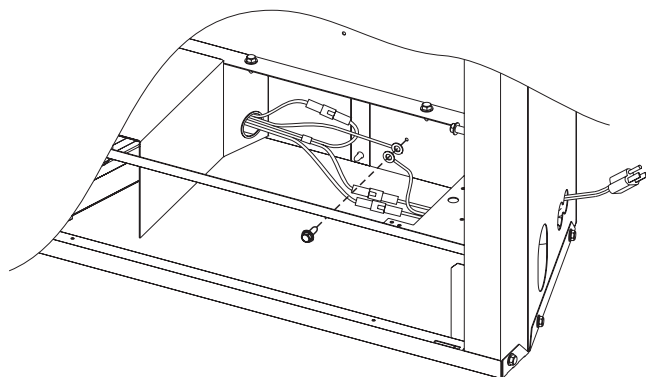

Figure 27

25. Position blower shield beneath left flange on burner assembly. Align clearance hole on left flange of burner assembly with screw hole on blower side shield.
26. Replace burner assembly.
27. Attach burner assembly to blower shield with one (1) 10 x 1/2" screw. See Figure 28.

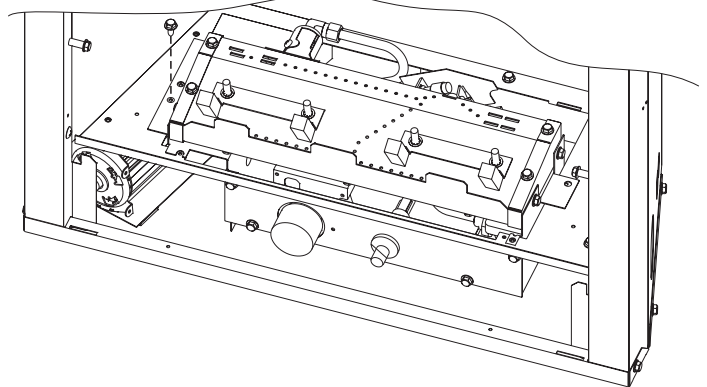

Figure 28

28. Replace burner assembly [four (4) 10 x 1/2" screws].
29. Remove 10 x 1/2" screw (if present) located on left, front of valve cover on burner assembly. Insert blower shield front adjacent to blower motor and blower shield side. Align clearance hole on blower shield front with left, front screw hole on valve cover. Attach blower shield front to valve cover with two (2) 10 x 1/2" screw. See Figure 29.

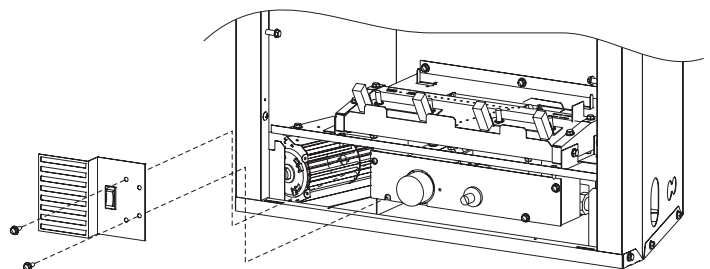

Figure 29

OPTIONAL BLOWER INSTALLATION INSTRUCTIONS (cont.)

30. Attach rear log support to inner casing with three (3) 10 x 1/2" screws from step 4.
31. Place and align blower diverter on top of inner casing. Attach deflector to top of inner casing with two (2) 10 x 1/2" screws. See Figure 30.

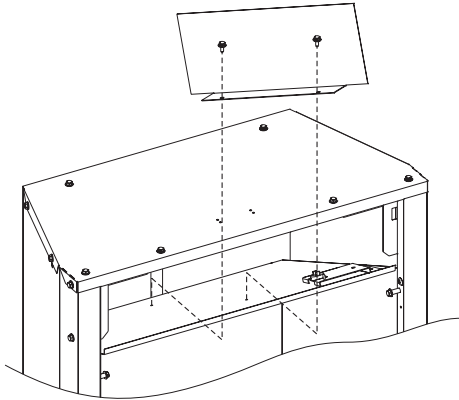

Figure 30

32. Replace bottom louver.
33. Replace upper louver.
34. Replace screen front by lifting upward on screen front.
35. Attach wiring diagram label to inside of heater base.

Wiring

The appliance, when installed, must be electrically grounded in accordance with local codes or, in the absence of local codes, with the *National Electrical Code ANSI/NFPA No. 70*, if an external electrical source is utilized. **This appliance is equipped with a three-prong [grounding] plug for your protection against shock hazard and should be plugged directly into a properly grounded three-prong receptacle. Do not cut or remove the grounding prong from this plug.** For an ungrounded receptacle, an adapter, which has two prongs and a wire for grounding, can be purchased, plugged into the ungrounded receptacle and its wire connected to the receptacle mounting screw. With this wire completing the ground, the appliance cord plug can be plugged into the adapter and be electrically grounded.

⚠ CAUTION

Label all wires prior to disconnection when servicing controls. Wiring errors can cause improper and dangerous operation. Verify proper operation after servicing.

Oiling Blower Motor

The blower motor does not have oiling holes. Do not attempt to oil the blower motor.

⚠ WARNING

Unplugging of blower accessory will not stop the heater from cycling. To turn off gas to the unvented heater: Push in gas control knob slightly and turn clockwise to "OFF." Do not force.

EMPIRE COMFORT SYSTEMS WIRING DIAGRAM

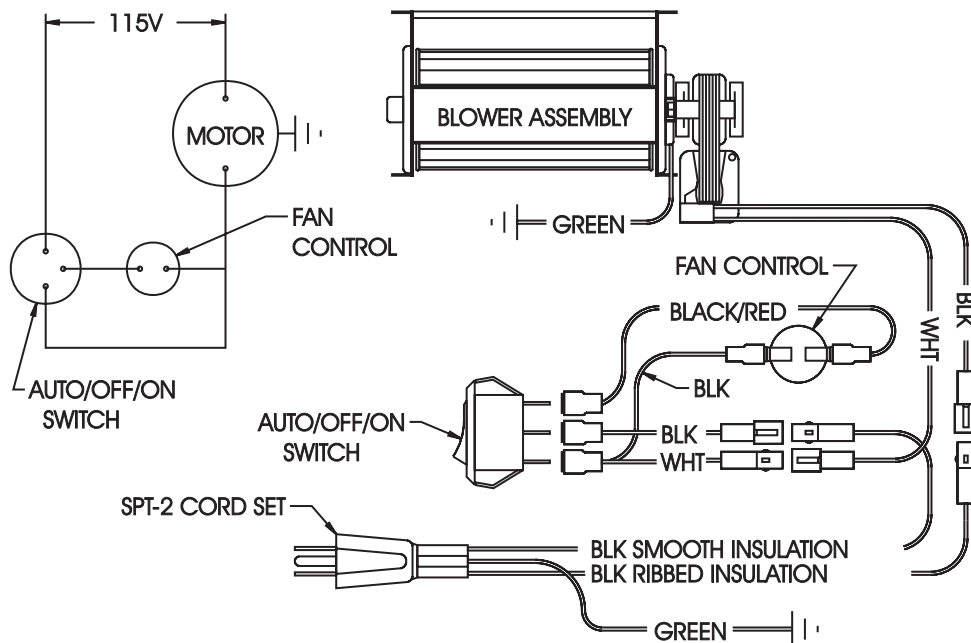

IF ANY OF THE ORIGINAL WIRE AS SUPPLIED WITH THIS UNIT MUST BE REPLACED, IT MUST BE REPLACED WITH NO. 18 GAGE 150°C 2/64 INSULATION WIRE OR ITS EQUIVALENT.

Figure 31

OPTIONAL BLOWER INSTALLATION INSTRUCTIONS (cont.)

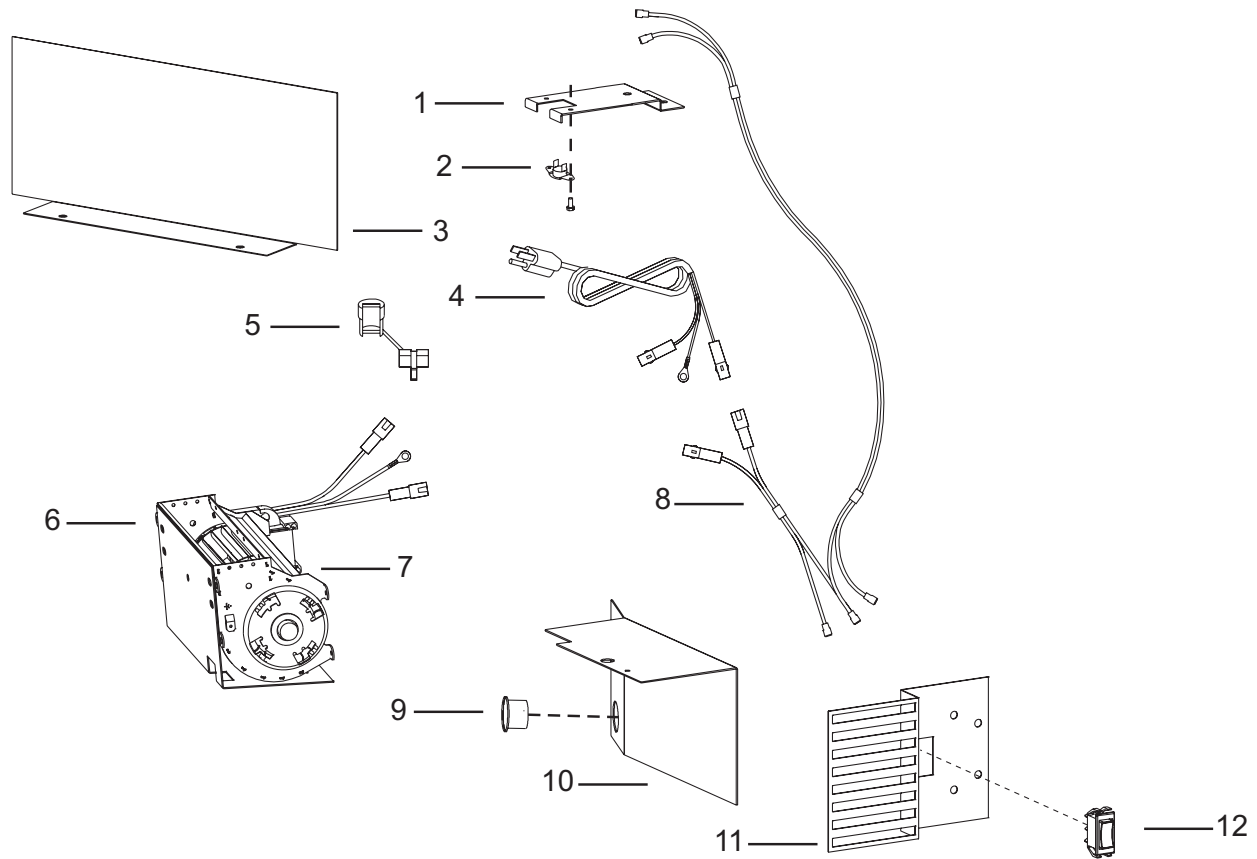

FBB6 PARTS LIST

Index No.	Part Number	Description
1	11508	FAN CONTROL BRACKET
2	R2503	FAN CONTROL
3	11301	BLOWER DIVERTER
4	R2099	CORD SET
5	R1410	STRAIN RELIEF BUSHING
6	25794	BLOWER BASE ASSEMBLY
7	R2804A	BLOWER ASSEMBLY
8	R5804	WIRE HARNESS
9	R1404	SNAP BUSHING
10	11507	BLOWER SHIELD - SIDE
11	25795	BLOWER SIDE -FRONT
12	R2805	AUTO/OFF/ON SWITCH

PARTS LIST AND PARTS VIEW FOR OPTIONAL TRIM KITS

Attention: When ordering parts, it is very important that the part number and description coincide.

Index Number	Part Number	Description
VFF24BR Brass Trim Kit		
1	25974	Trim Top
2	25972	Trim Left
3	25973	Trim Right
VFF24SS Stainless Steel Trim Kit		
1	25982	Trim Top
2	25980	Trim Left
3	25981	Trim Right
VFF24HP Hammered Pewter Trim Kit		
1	25978	Trim Top
2	25976	Trim Left
3	25977	Trim Right

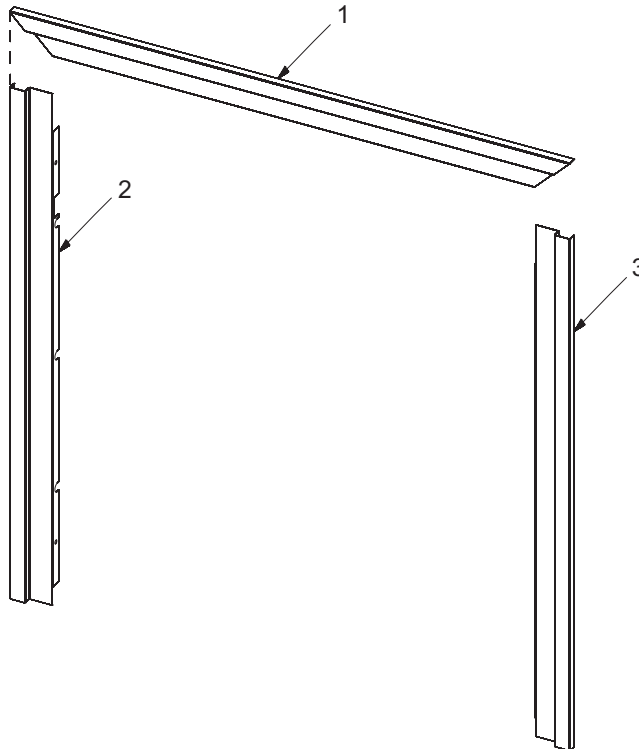

MASTER PARTS DISTRIBUTOR LIST

To Order Parts Under Warranty, please contact your local Empire dealer. See the dealer locator at www.empirecomfort.com. To provide warranty service, your dealer will need your name and address, purchase date and serial number, and the nature of the problem with the unit.

To Order Parts After the Warranty Period, please contact your dealer or one of the Master Parts Distributors listed below. This list changes from time to time. For the current list, please click on the Master Parts button at www.empirecomfort.com.

Please note: Master Parts Distributors are independent businesses that stock the most commonly ordered Original Equipment repair parts for Heaters, Grills, and Fireplaces manufactured by Empire Comfort Systems Inc.

Dey Distributing

1401 Willow Lake Boulevard
Vadnais Heights, MN 55101

Phone: 651-490-9191

Toll Free: 800-397-1339

Website: www.deydistributing.com

Parts: Heater & Hearth

East Coast Energy Products

10 East Route 36
West Long Branch, NJ 07764

Phone: 732-870-8809

Toll Free: 800-755-8809

Fax: 732-870-8811

Website: www.eastcoastenergy.com

Parts: Heater & Hearth and Grills

Victor Division of F. W. Webb Company

200 Locust Street
Hartford, CT 06114

Phone: 860-722-2433

Toll Free: 800-243-9360

Fax: 860-293-0479

Toll Free Fax: 800-274-2004

Websites: www.fwwebb.com & www.victormfg.com

Parts: Heater & Hearth and Grills

HOW TO ORDER REPAIR PARTS

Parts Not Under Warranty

Parts can be ordered through your Service Person, Dealer, or a Master Parts Distributor. See this page for the Master Parts Distributors list. For best results, the **service person or dealer** should order parts through the distributor. Parts can be shipped directly to the **service person/dealer**.

Warranty Parts

Warranty parts will need a proof of purchase and can be ordered by your Service Person or Dealer. Proof of purchase is **required** for warranty parts.

All parts listed in the Parts List have a Part Number. When ordering parts, first obtain the Model Number and Serial Number from the name plate on your equipment. Then determine the Part Number (**not** the Index Number) and the Description of each part from the following illustration and part list. Be sure to give all this information . . .

Appliance Model Number _____ Part Description _____

Appliance Serial Number _____ Part Number _____

Type of Gas (Propane or Natural) _____

Do not order bolts, screws, washers or nuts. They are standard hardware items and can be purchased at any local hardware store.

Shipments contingent upon strikes, fires and all causes beyond our control.



Empire Comfort Systems Inc.
918 Freeburg Ave. Belleville, IL 62220

If you have a general question about our products, please e-mail us at
info@empirecomfort.com.

If you have a service or repair question, please contact your dealer.

www.empirecomfort.com